



### Letter-Sound Match



#### Objective

The student will match initial, final, and medial phonemes to graphemes.



#### Materials

- ▶ Picture cards (Activity Master P.025.AM1)  
*Note: The pictures used are: ant, map, pin, bib, bug, dog, cry, leg, fly, sun*
- ▶ Student sheet (Activity Master P.025.SS1)
- ▶ Scissors
- ▶ Glue



#### Activity

Students sort pictures by matching phonemes to graphemes and write missing letters.

1. Provide the student with a student sheet and picture card Activity Master. Place scissors and glue at the center.
2. The student cuts out the pictures. Selects a picture, names it, and says each sound (e.g., “bug, /b//u//g/”).
3. Looks for the letters that correspond to two of the sounds.
4. Glues the picture in the fourth column next to the two letters. Looks at the blank space in the row, determines the missing sound, and writes the corresponding letter (i.e., “/b//u//g/, the missing letter is g”).
5. Continues until all blanks are filled.
6. Teacher evaluation

Name \_\_\_\_\_

Letter-Sound Match P.025.SS1

m		p	picture
	i	n	picture
b	u		
a		t	picture
b	i		picture
s	u		picture
c		y	picture
	e	g	picture
f		y	picture
	o	g	picture



#### Extensions and Adaptations

- ▶ Use other pictures and words (Activity Master P.025.SS2).

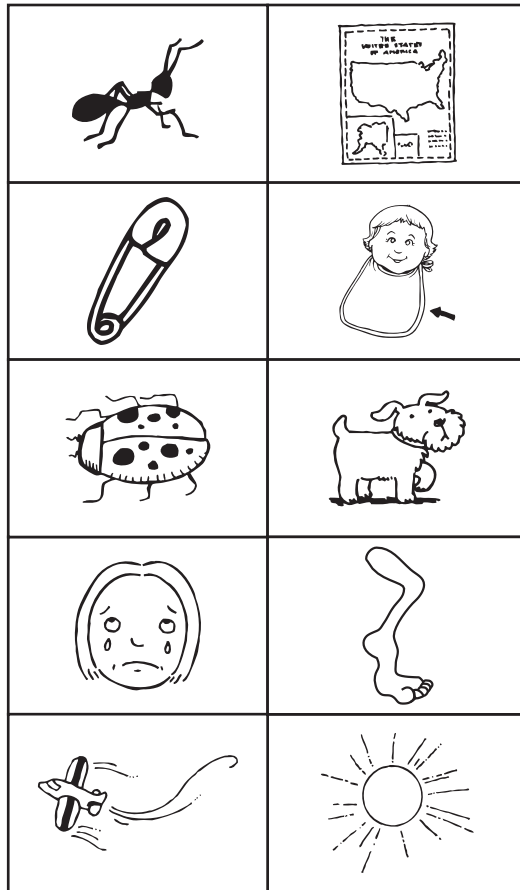

Name \_\_\_\_\_

Letter-Sound Match

P.025.SS I

m		p	picture
	i	n	picture
b	u		picture
a		t	picture
b	i		picture
s	u		picture
c		y	picture
	e	g	picture
f		y	picture
	o	g	picture

# Name \_\_\_\_\_

**P.025.SS2**

Picture Letter-Sound Match

			picture
			picture
			picture
			picture
			picture
			picture
			picture
			picture
			picture
			picture
			picture

# Phonics

Letter-Sound Correspondence Cards – Initial

P.LSC-I.1

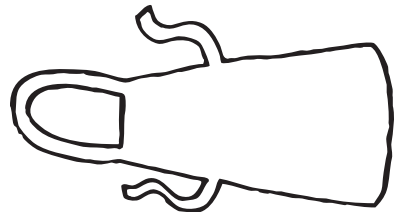
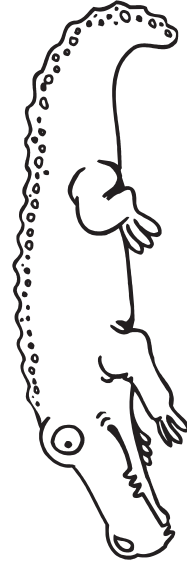
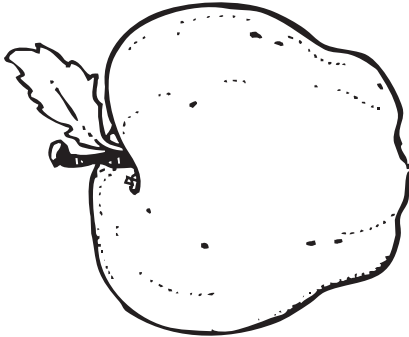
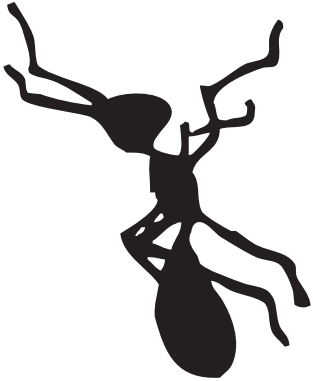

ant, apple, alligator, ax, ape, apron



P.LSC-I.2

Letter-Sound Correspondence Cards – Initial

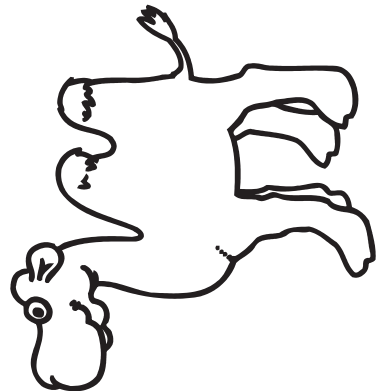
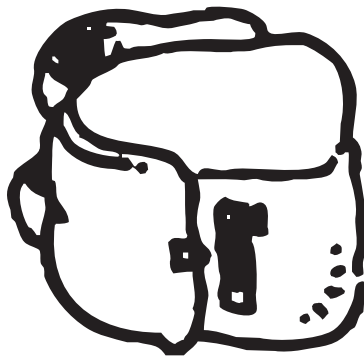
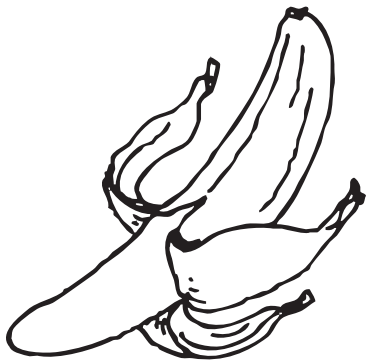
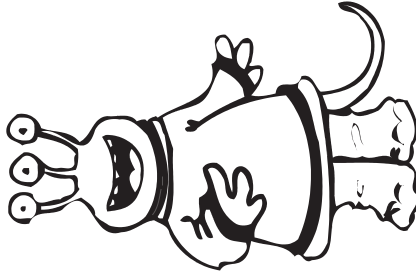
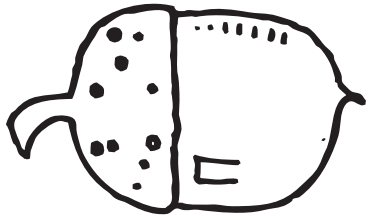

acorn, alien, beach, banana, backpack, camel



# Phonics

Letter-Sound Correspondence Cards – Initial

P.LSC-I.3

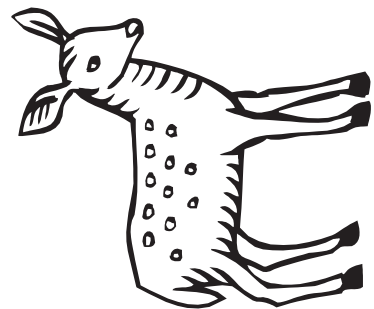
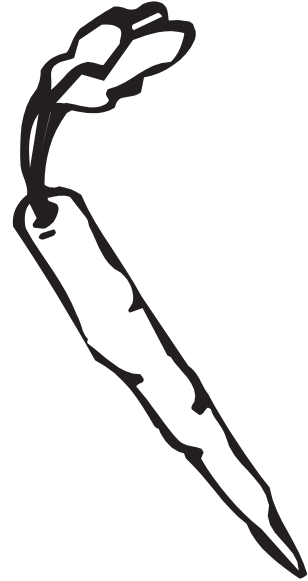
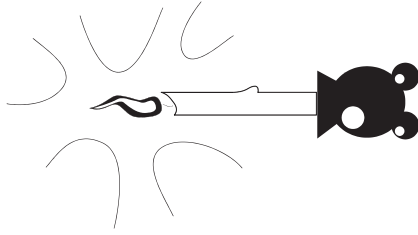

cane, candle, carrot, doughnut, dragon, deer



P.LSC-I.4

Letter-Sound Correspondence Cards – Initial

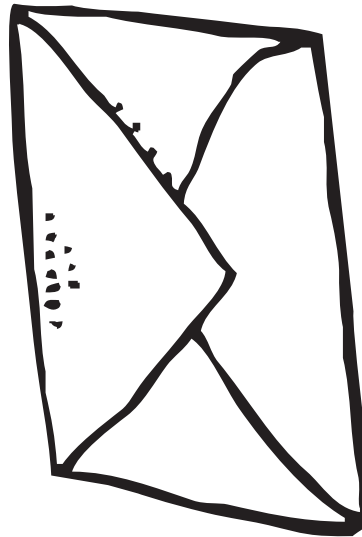
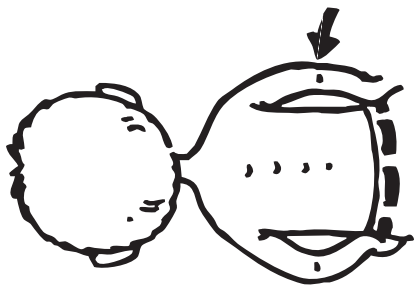
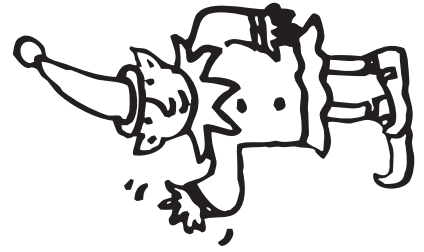
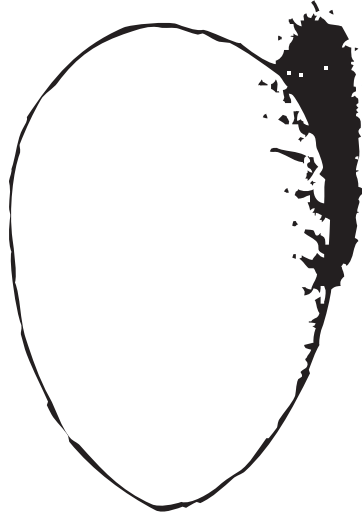
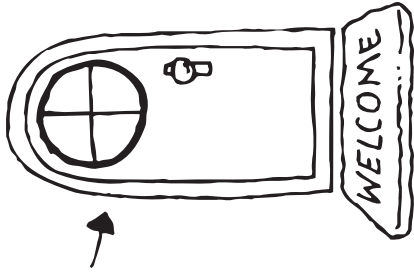

2+2 = 4

door, egg, elf, elbow, envelope, equal





# Phonics

Letter-Sound Correspondence Cards – Initial

P.LSC-I.5

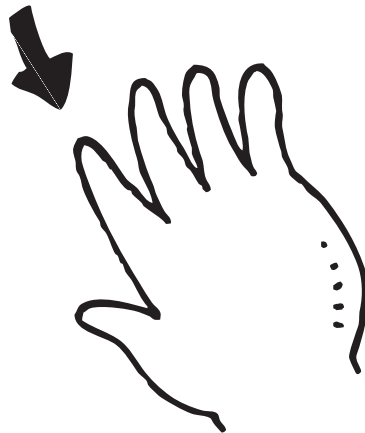
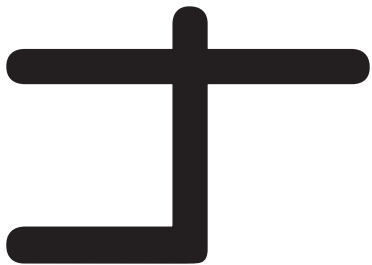
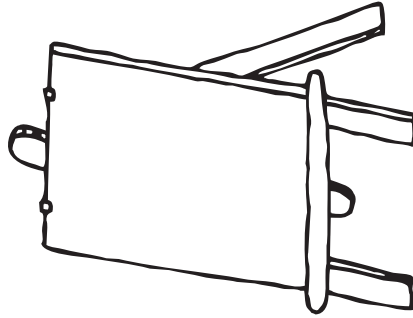

eagle, easel, eat, four, finger, feather



P.LSC-I.6

Letter-Sound Correspondence Cards – Initial

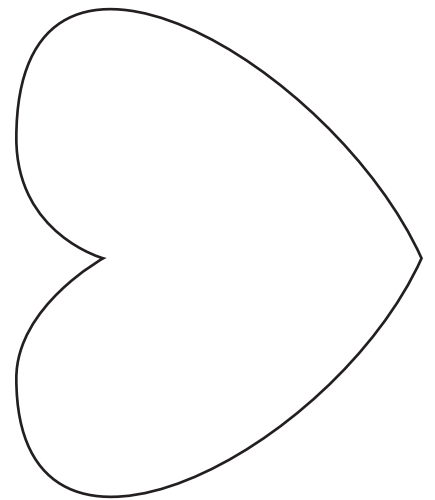
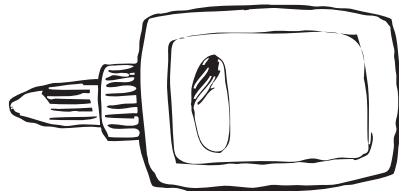
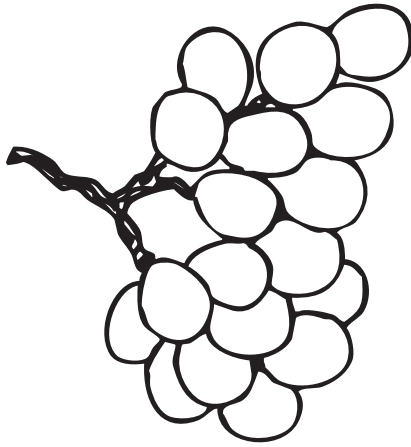
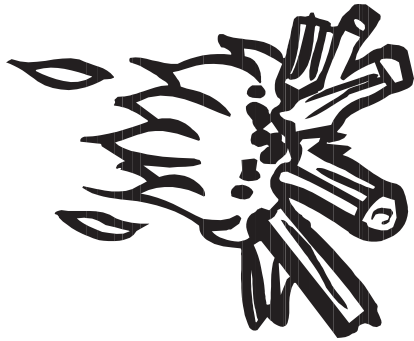

fire, grapes, guitar, gold, glue, heart



# Phonics

Letter-Sound Correspondence Cards – Initial

P.LSC-I.7

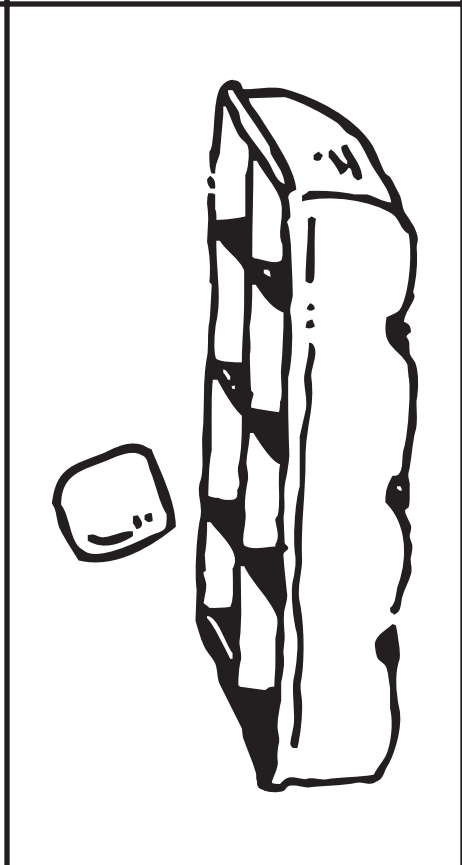
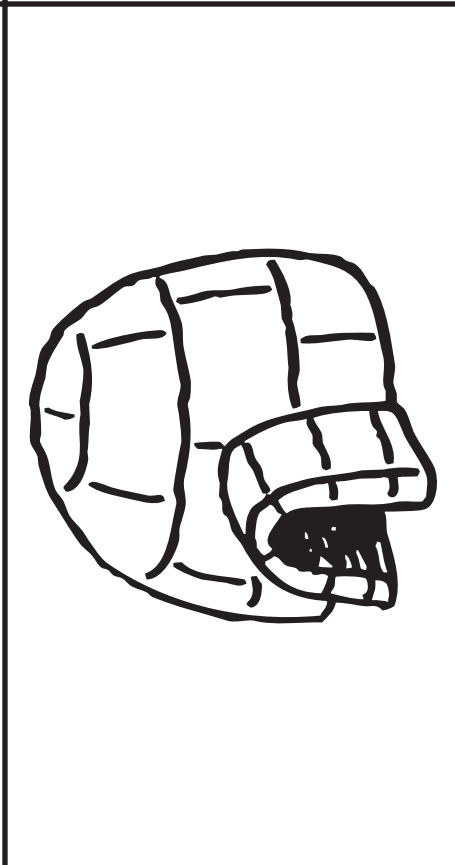
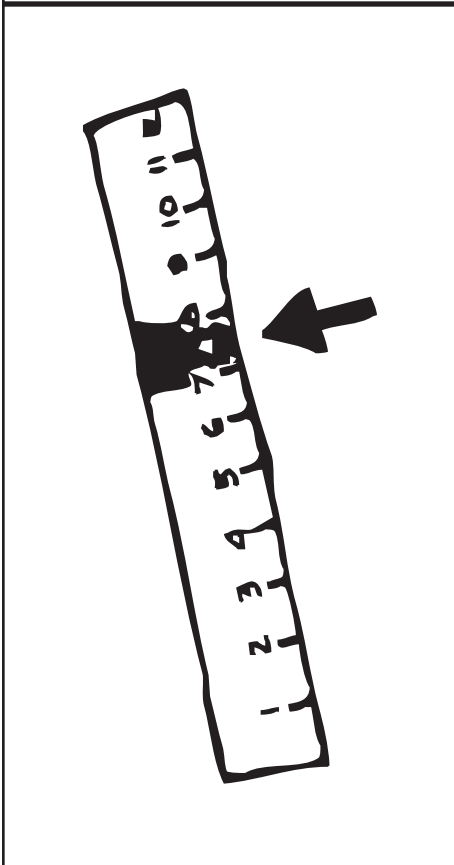
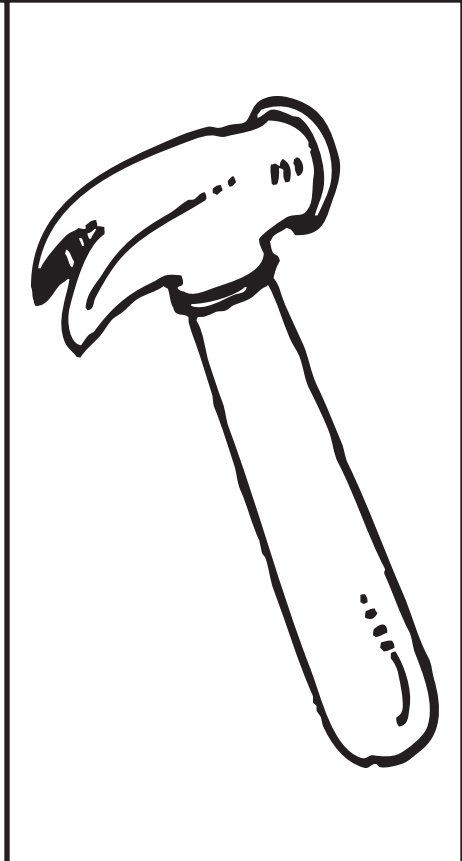
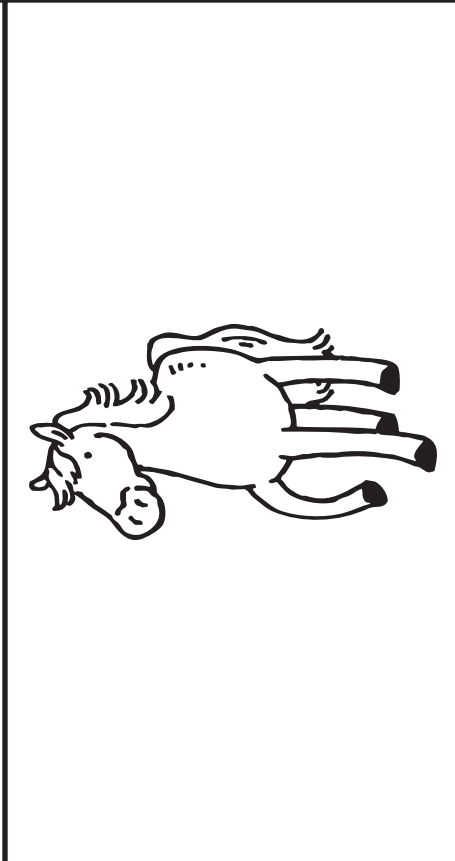

hippopotamus, horse, hammer, inch, igloo, ice



P.LSC-I.8

Letter-Sound Correspondence Cards – Initial

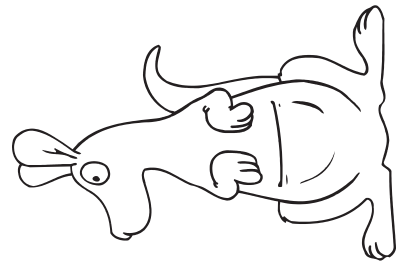
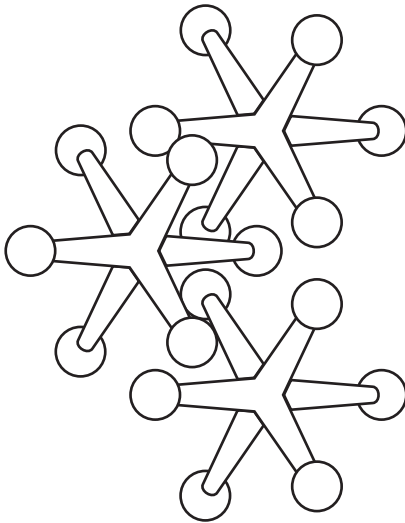
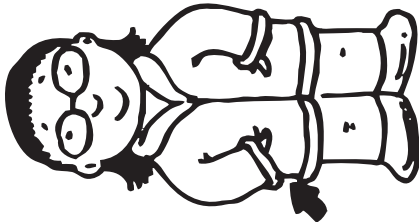
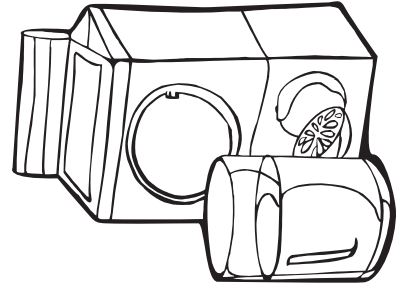
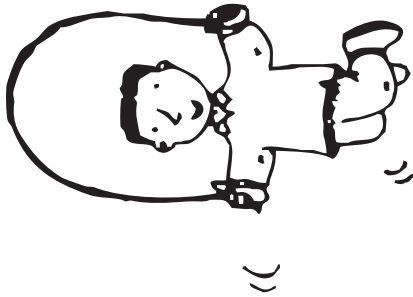
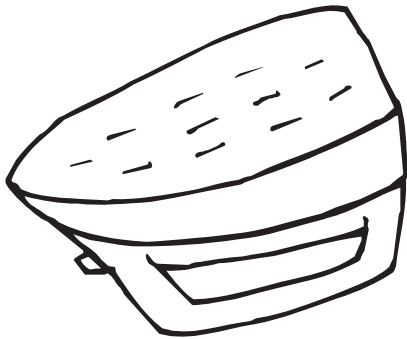

iron, jump, juice, jacket, jacks, kangaroo



# Phonics

Letter-Sound Correspondence Cards – Initial

P.LSC-I.9

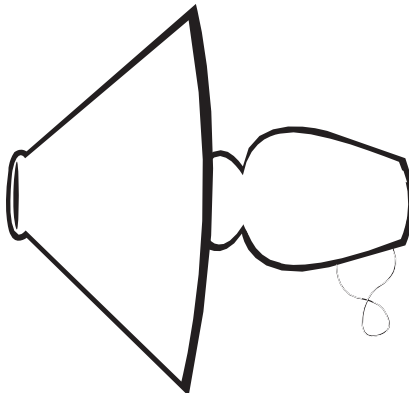
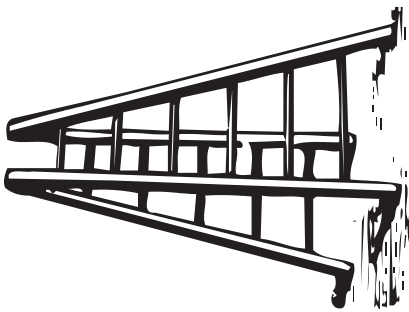
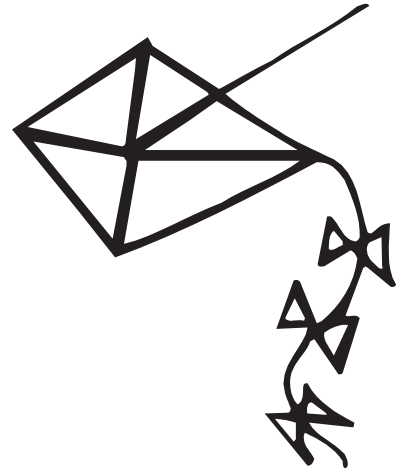
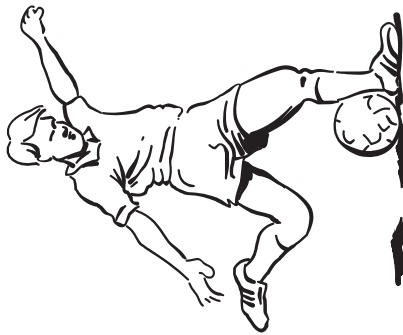
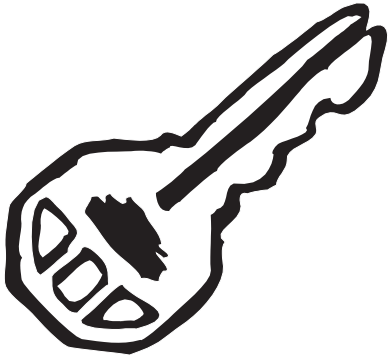

key, kick, kite, ladder, lamp, lion



P.LSC-I.10

Letter-Sound Correspondence Cards – Initial

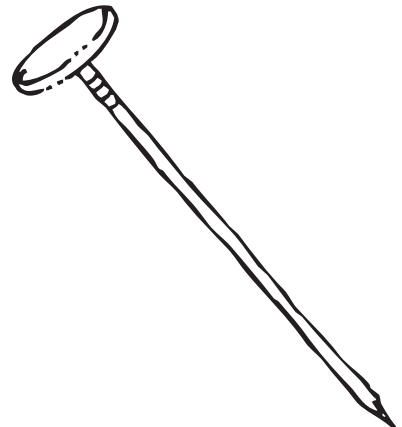
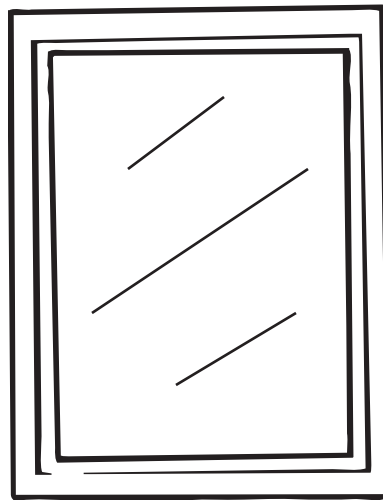
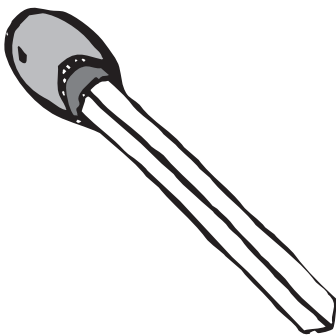
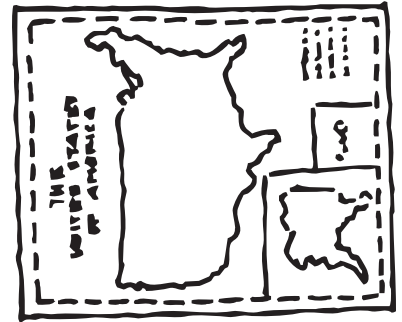
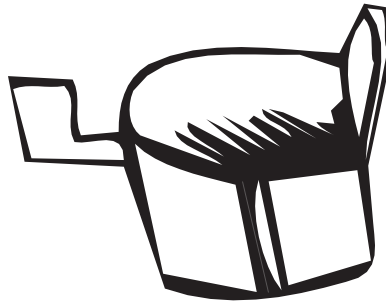
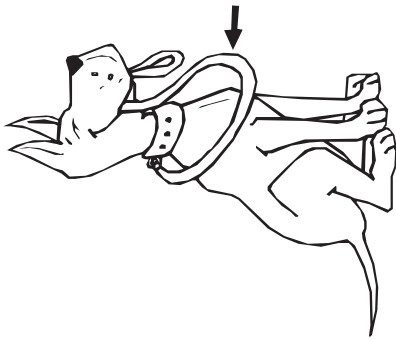

leash, mailbox, map, match, mirror, nail



# Phonics

Letter-Sound Correspondence Cards – Initial

P.LSC-I.1.1

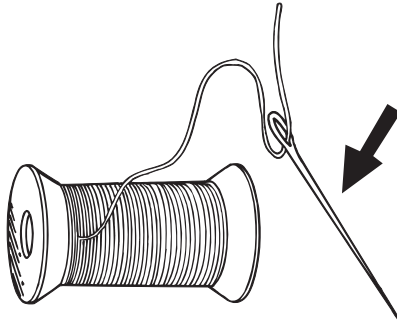
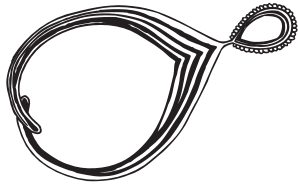

necklace, needle, nurse, octopus, ox, olive



P.LSC-I.12

Letter-Sound Correspondence Cards – Initial

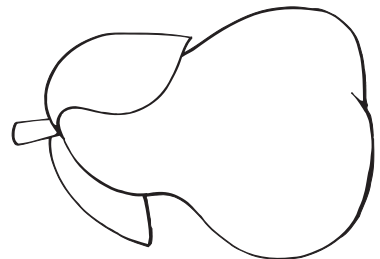
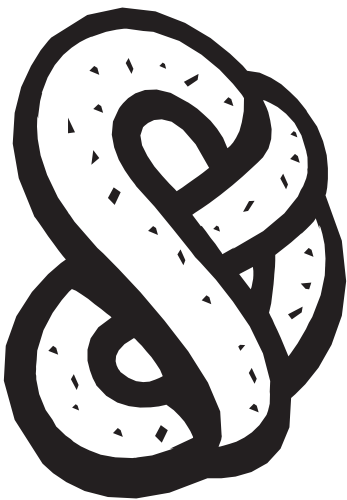
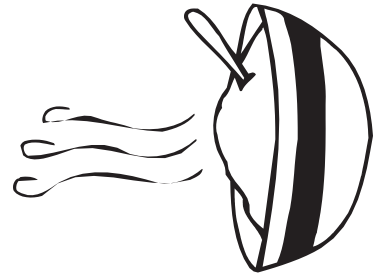
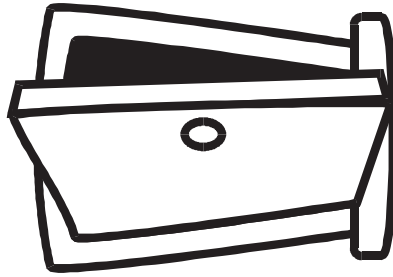

ostrich, open, oatmeal, pretzel, pillow, pear





# Phonics

Letter-Sound Correspondence Cards – Initial

P.LSC-I.13

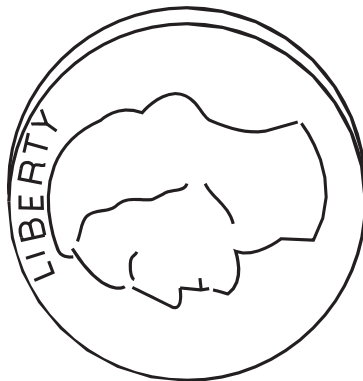
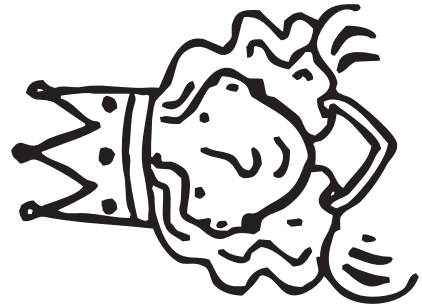
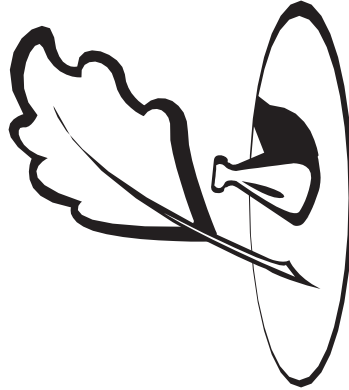
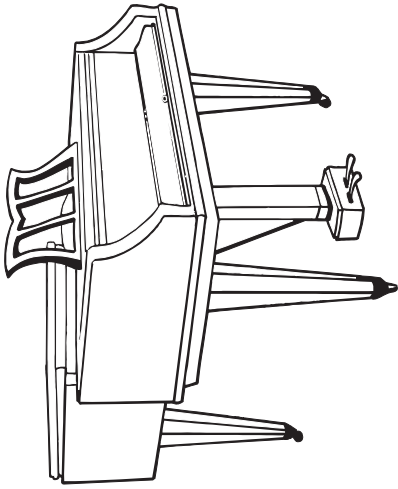

piano, quill, queen, question, quarter, rabbit



P.LSC-I.14

Letter-Sound Correspondence Cards – Initial

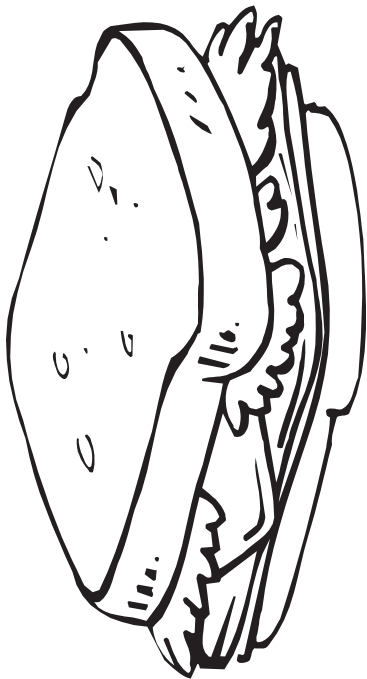
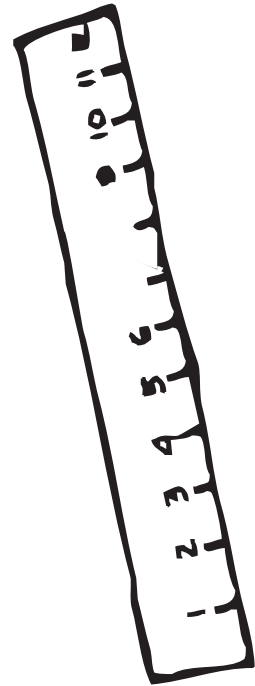
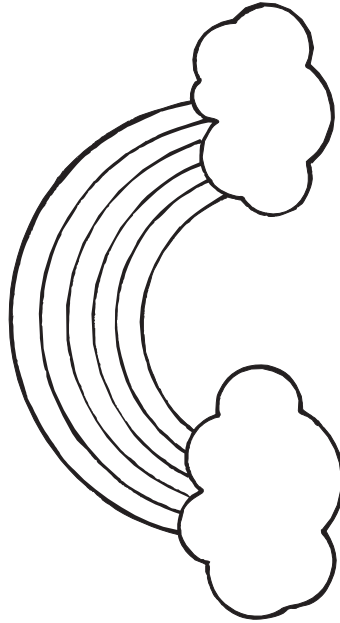
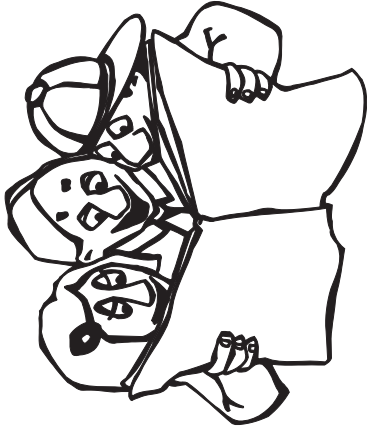

read, rainbow, ruler, sandwich, saw, seven



# Phonics

Letter-Sound Correspondence Cards – Initial

P.LSC-I.15

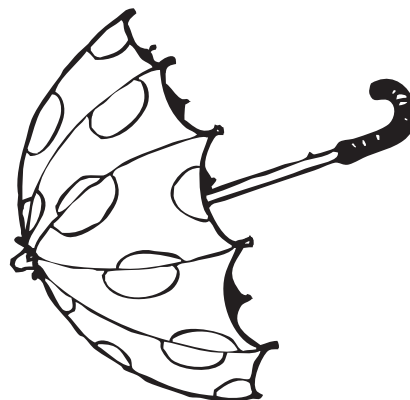
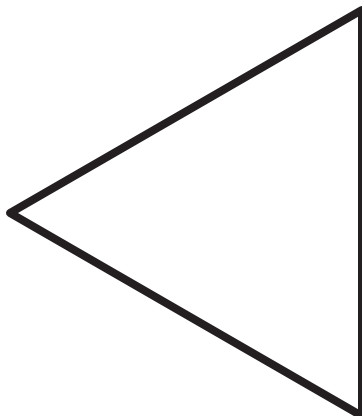
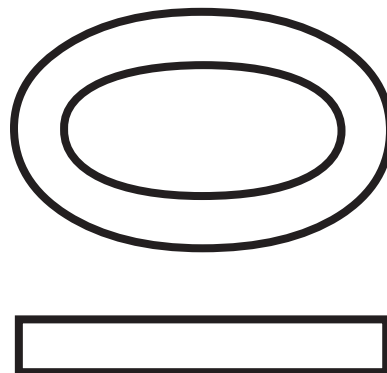
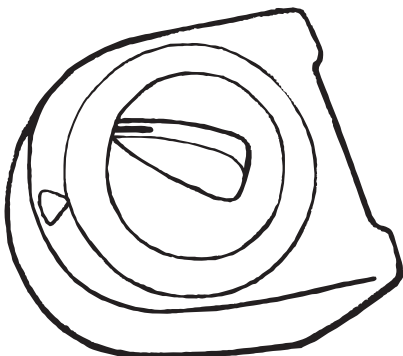

snake, timer, ten, tire, triangle, umbrella



P.LSC-I.16

Letter-Sound Correspondence Cards – Initial

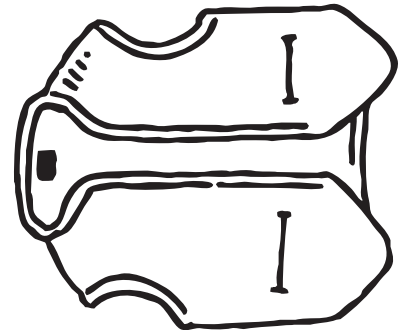
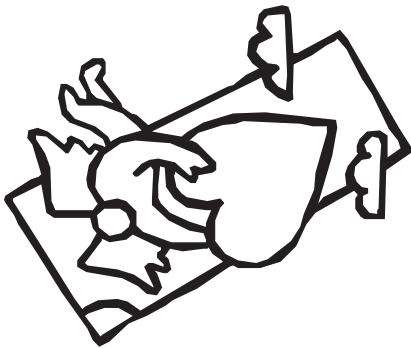
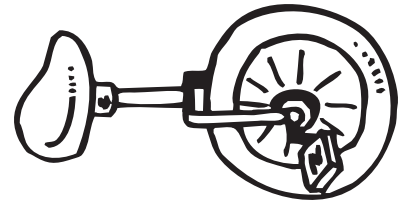
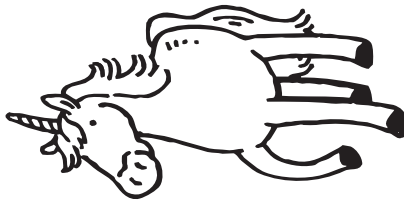

umpire, unicorn, unicycle, valentine, vacuum, vest



# Phonics

Letter-Sound Correspondence Cards – Initial

P.LSC-I.17

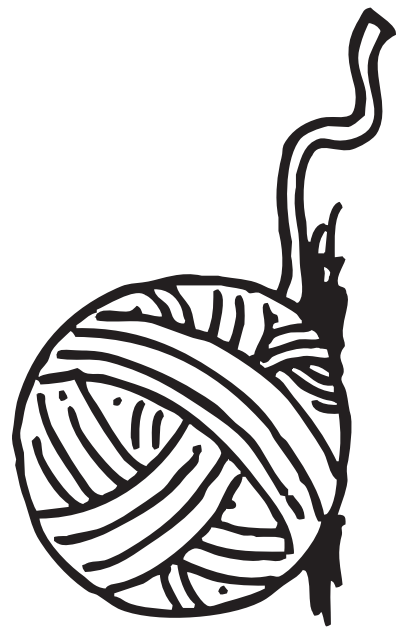
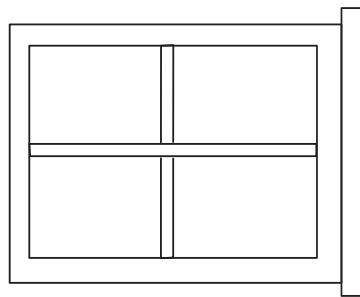
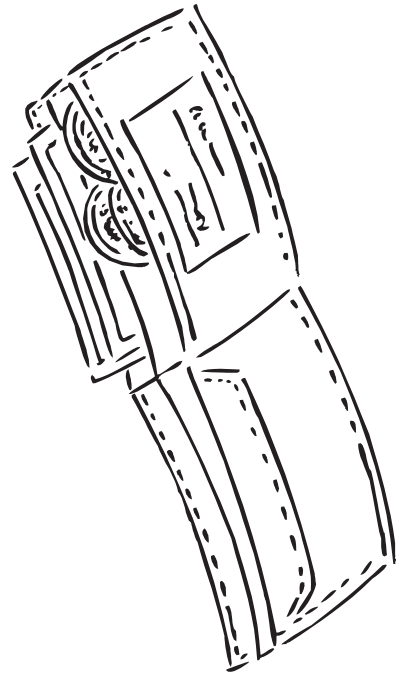
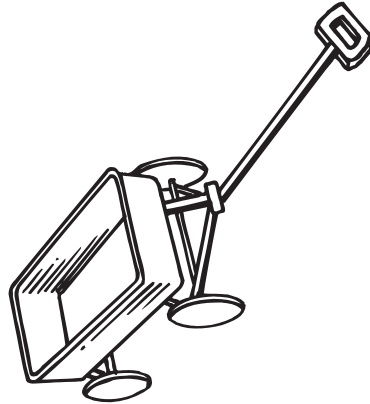
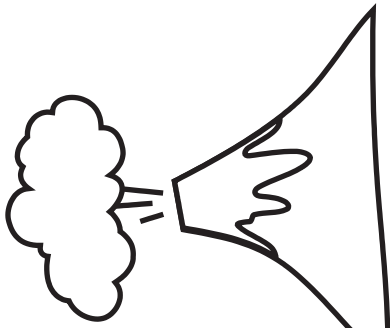

volcano, wagon, wallet, watch, window, yarn



P.LSC-I.18

Letter-Sound Correspondence Cards – Initial

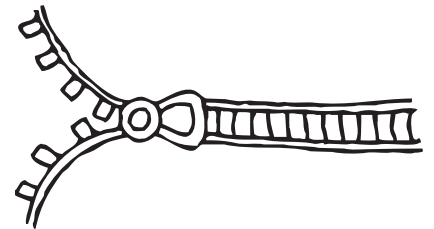
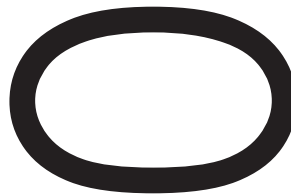
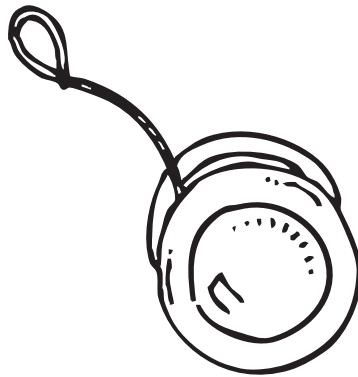
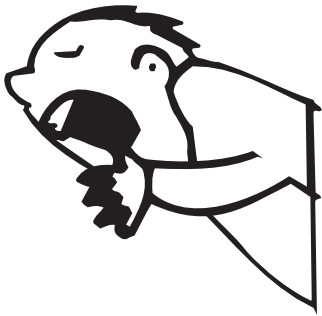

yawn, yo-yo, yak, zebra, zero, zipper



# Phonics

Letter-Sound Correspondence Cards – Initial

P.LSC-I.19

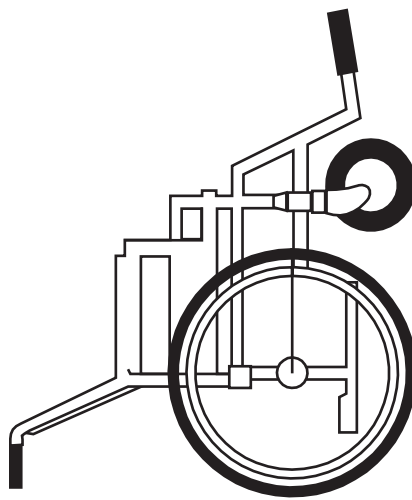
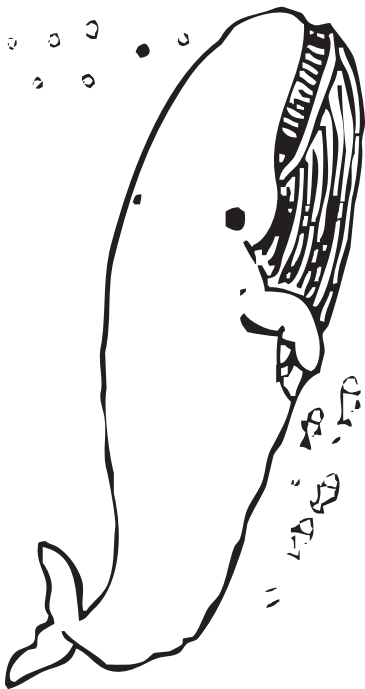
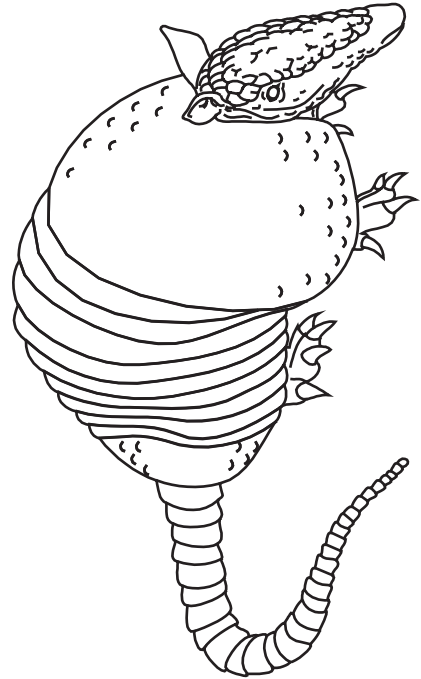
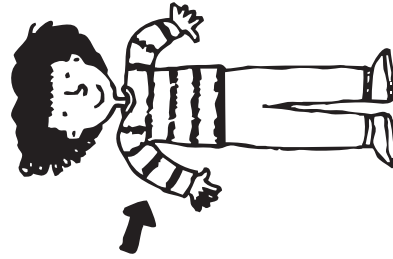

zoo, arm, armadillo, whale, wheelchair, whistle



P.LSC-I.20

Letter-Sound Correspondence Cards – Initial

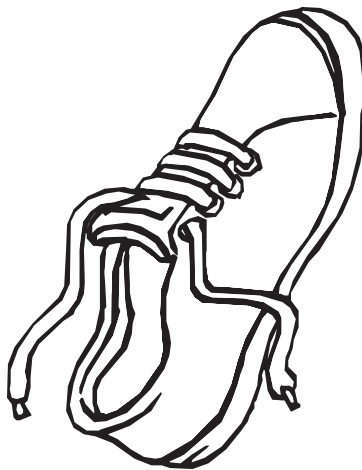
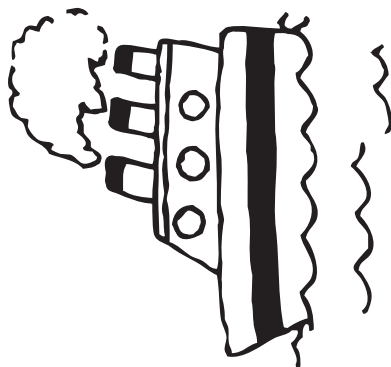
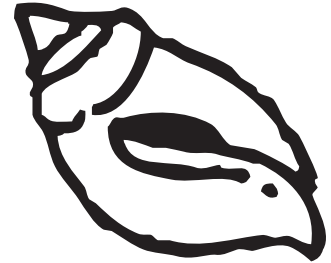
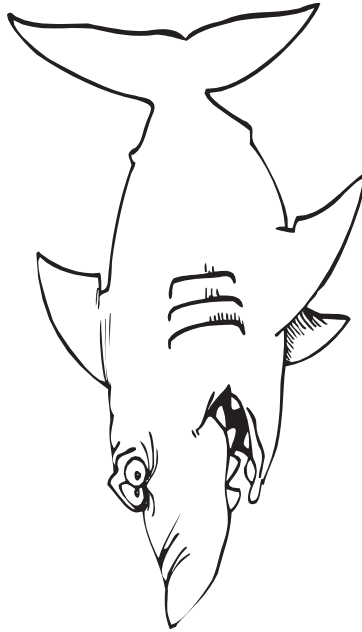
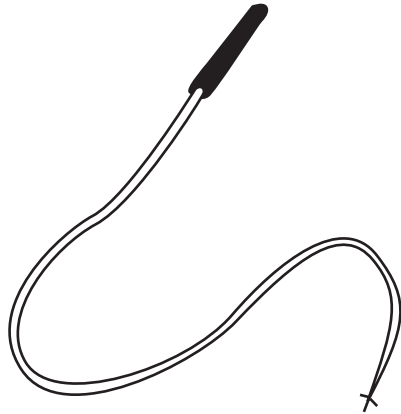

whip, shark, shell, ship, shoe, thermometer





# Phonics

Letter-Sound Correspondence Cards – Initial

P.LSC-I.2I

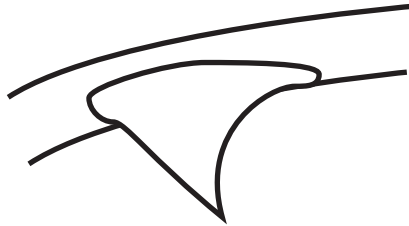
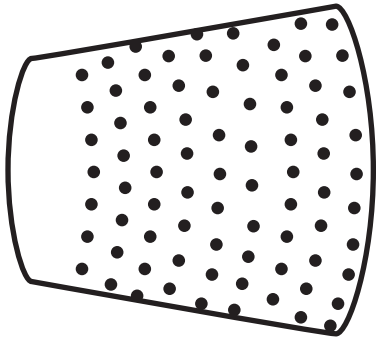

30

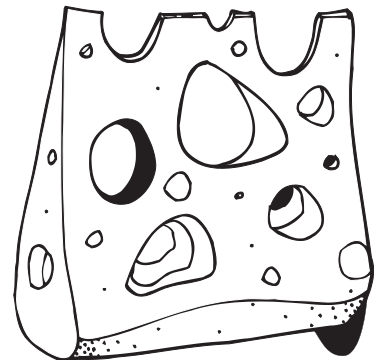
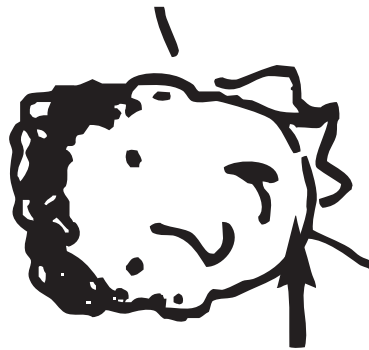
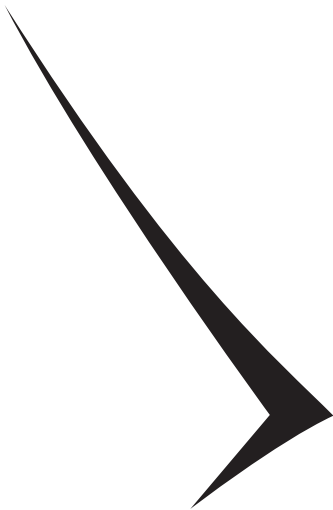

thimble, thorn, thirty, check, chin, cheese



P.LSC-I.22

Letter-Sound Correspondence Cards – Initial

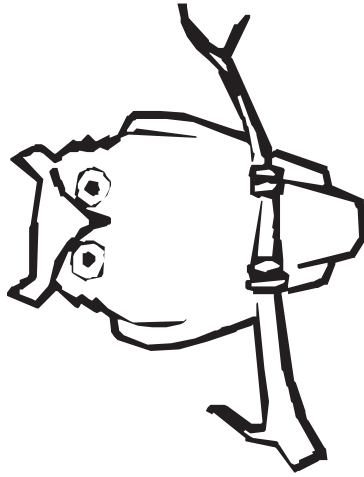
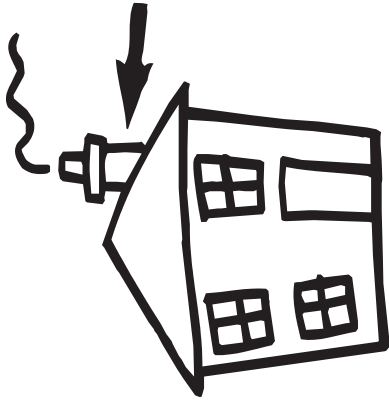

chimney, owl, ouch



# Phonics

Letter-Sound Correspondence Cards – Medial

P.LSC-M.1

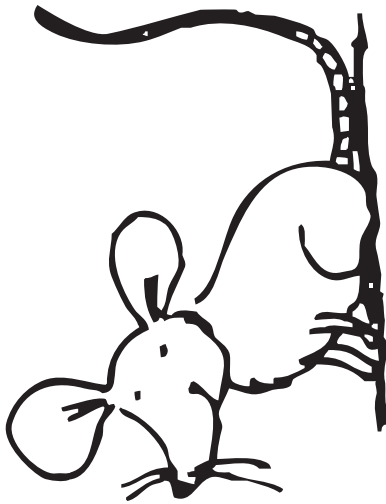
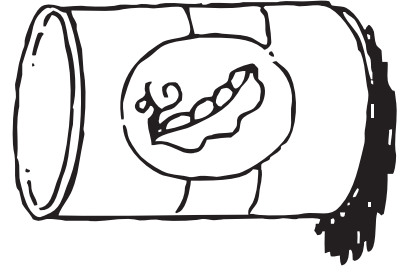
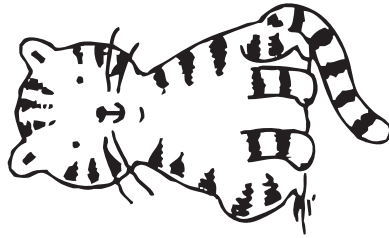
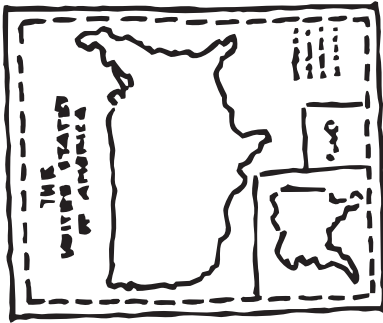

map, cat, can, rat, rain, gate



P.LSC-M.2

Letter-Sound Correspondence Cards – Medial

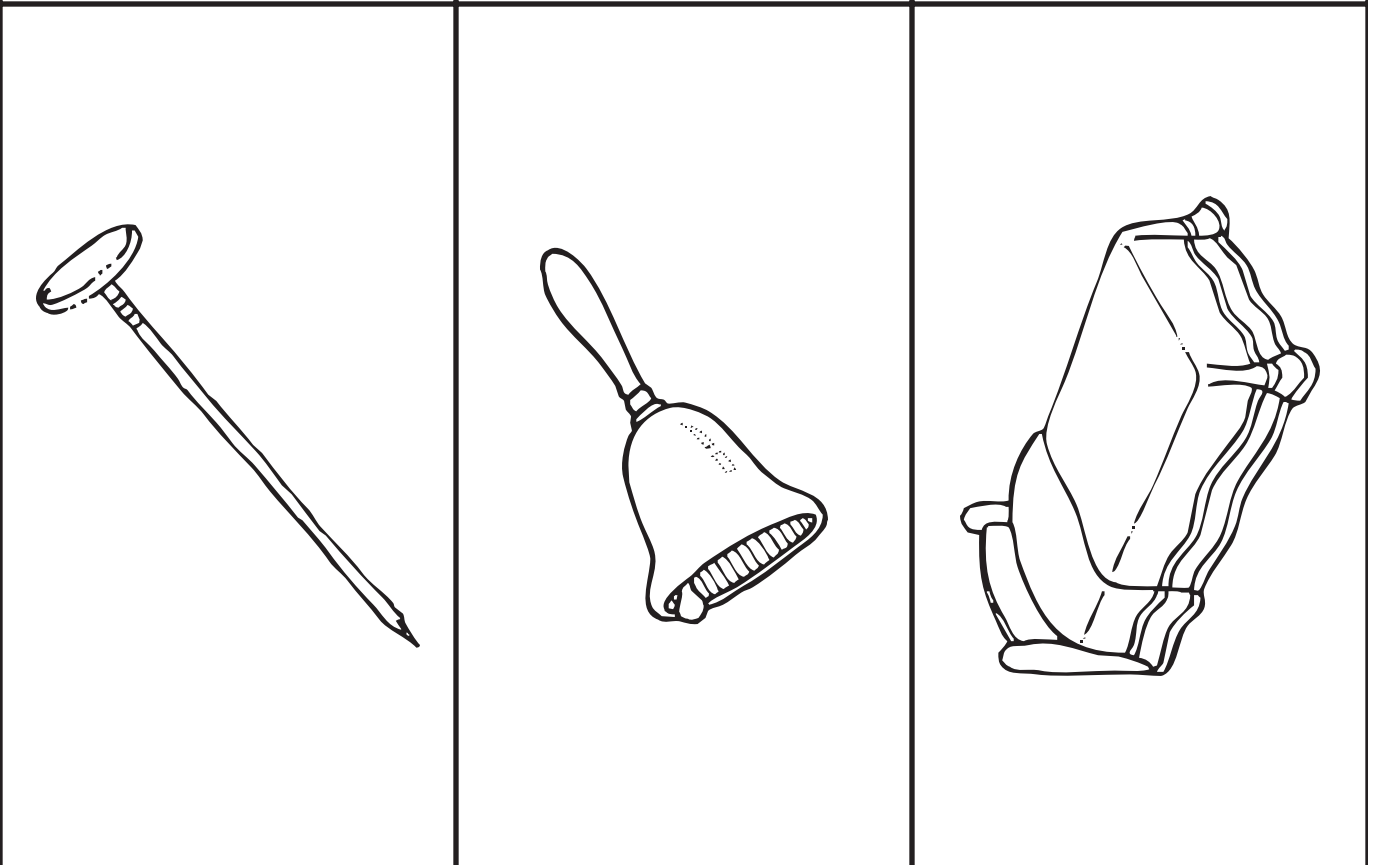
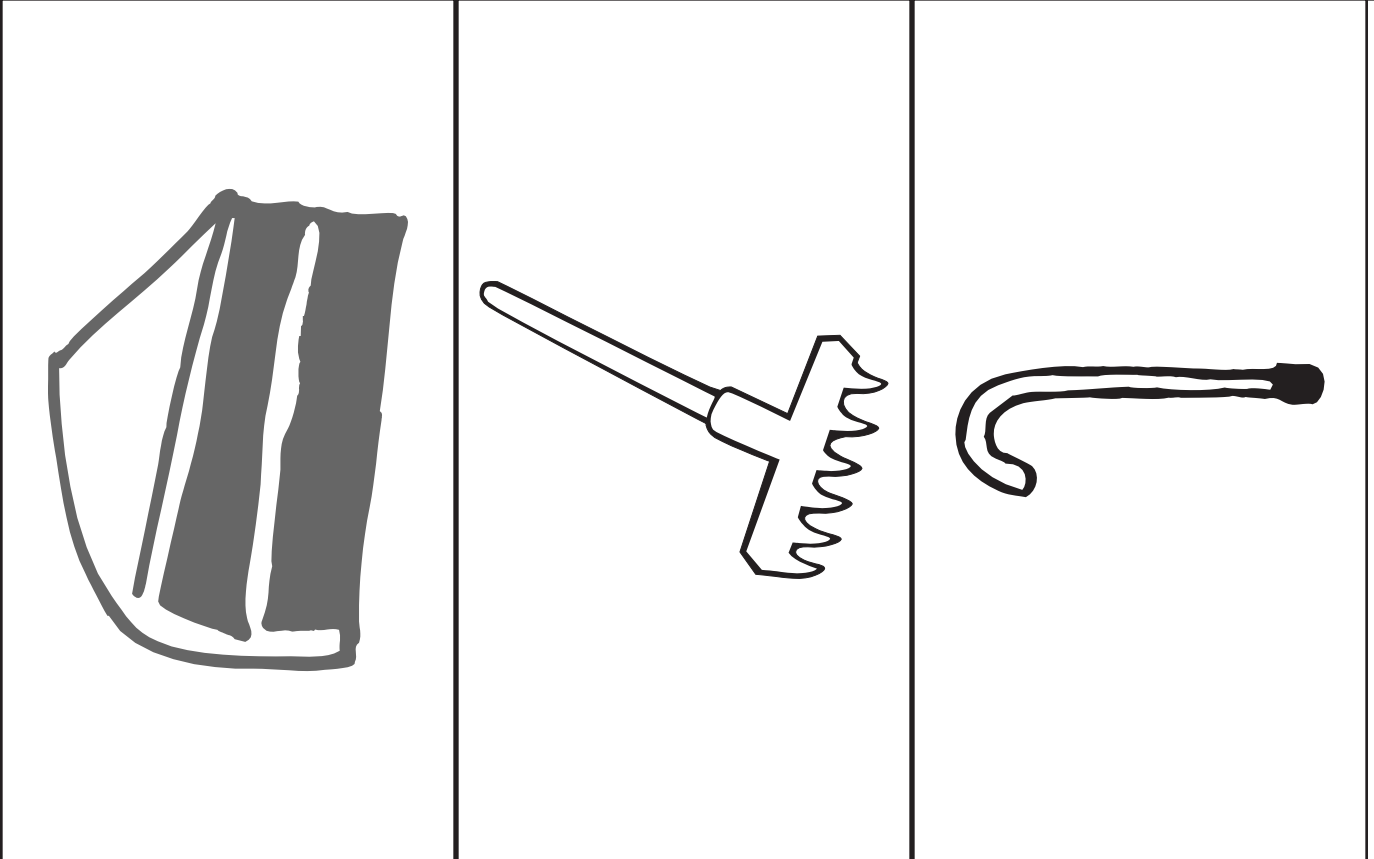

cake, rake, cane, nail, bell, bed



# Phonics

Letter-Sound Correspondence Cards – Medial

P.LSC-M.3

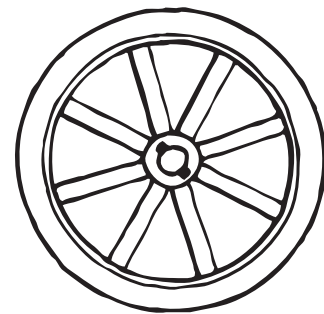
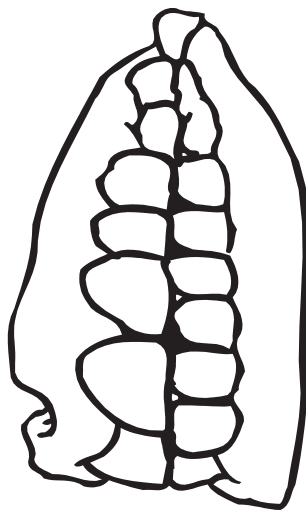
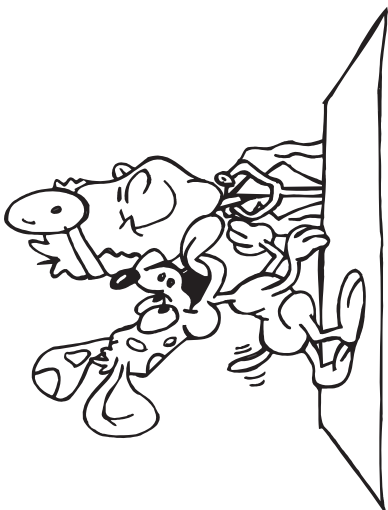
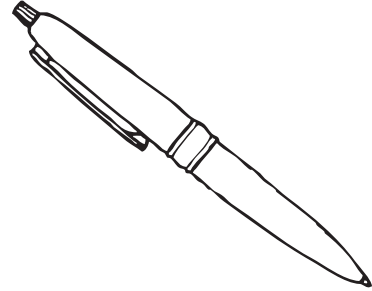
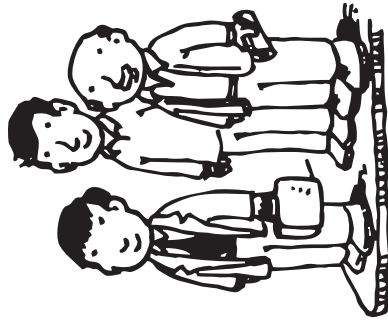
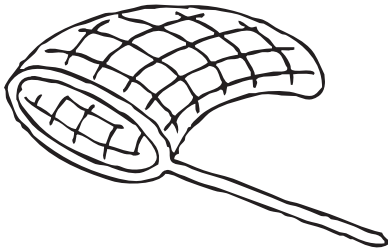

net, men, pen, vet, teeth, wheel



P.LSC-M.4

Letter-Sound Correspondence Cards – Medial

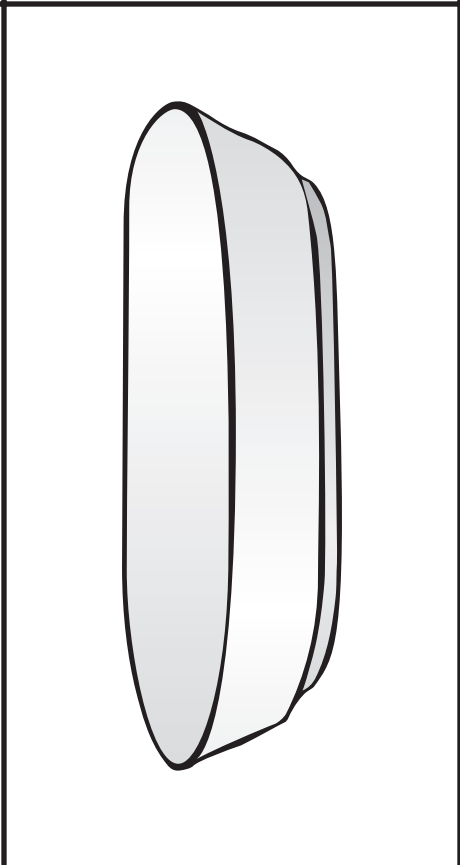
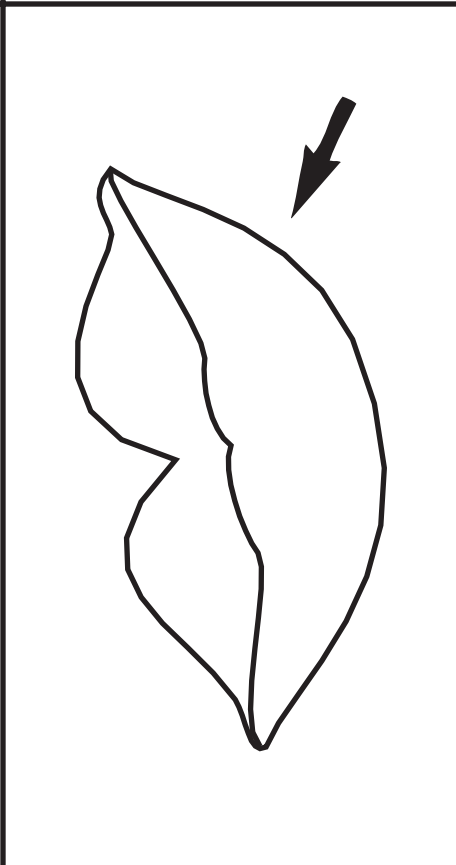
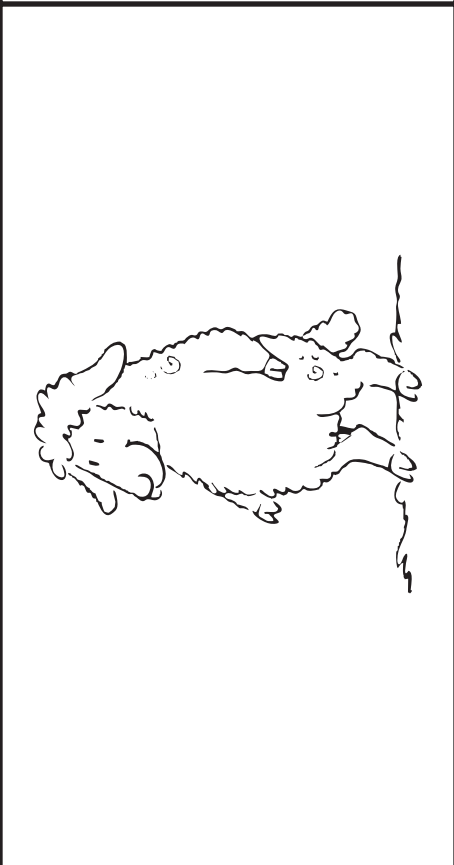
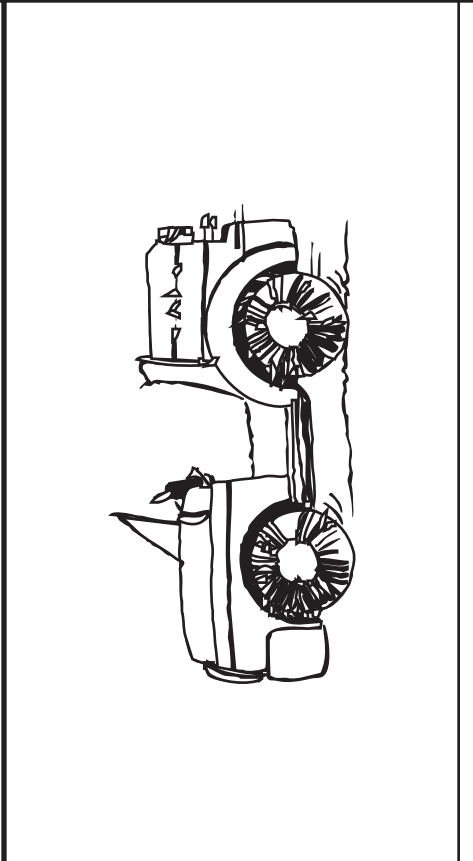
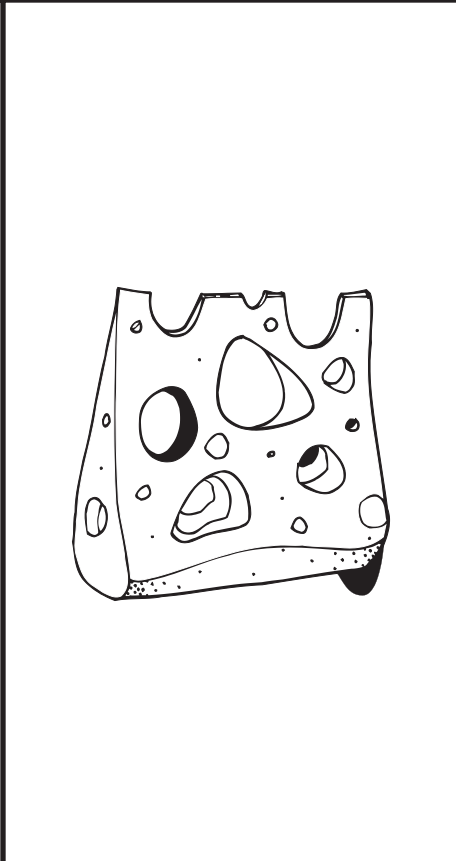
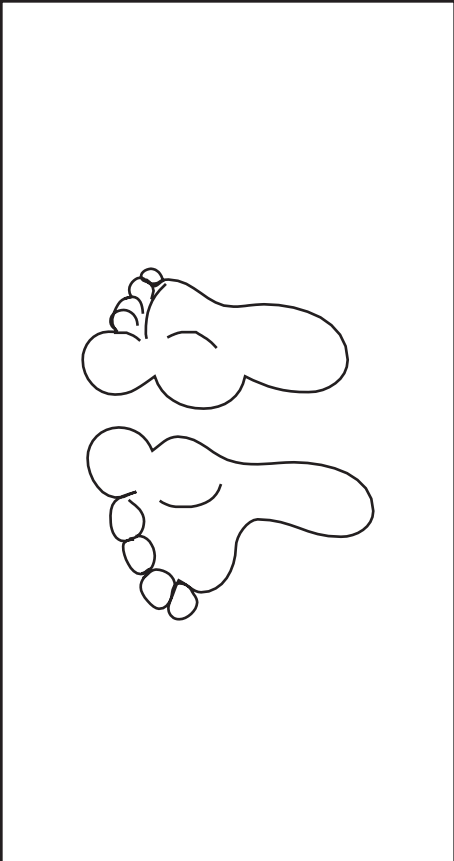

feet, cheese, jeep, sheep, lip, dish



# Phonics

Letter-Sound Correspondence Cards – Medial

P.LSC-M.5

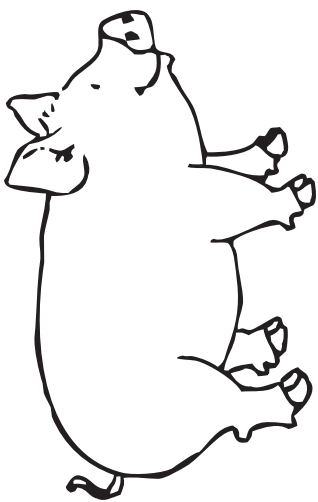
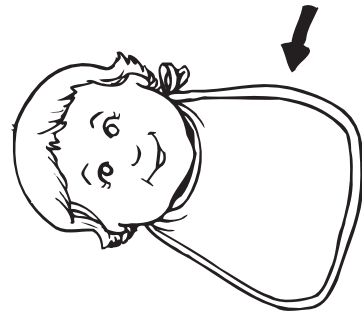
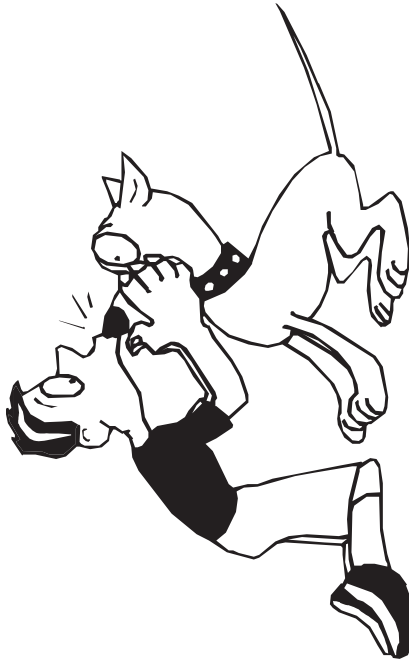
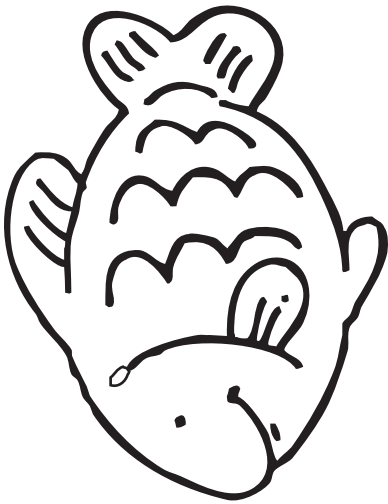

9

5

fish, kiss, bib, pig, nine, five



P.LSC-M.6

Letter-Sound Correspondence Cards – Medial

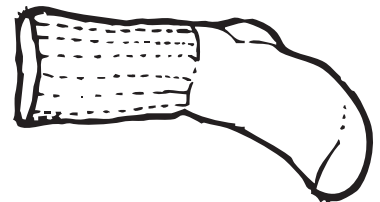
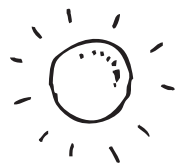
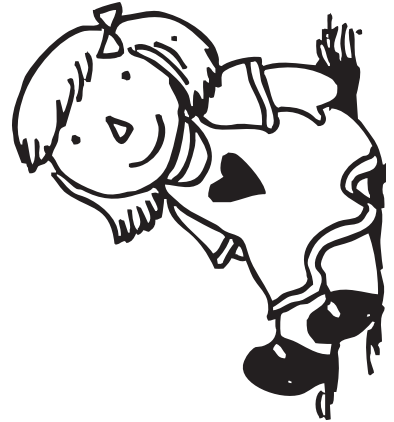
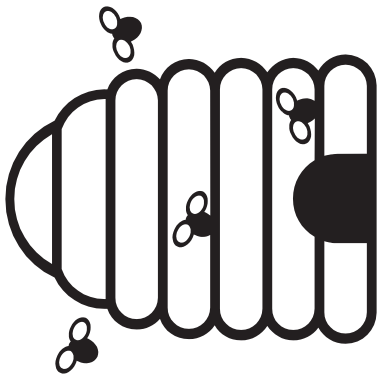

hive, mice, doll, dog, hot, sock





# Phonics

Letter-Sound Correspondence Cards – Medial

P.LSC-M.7

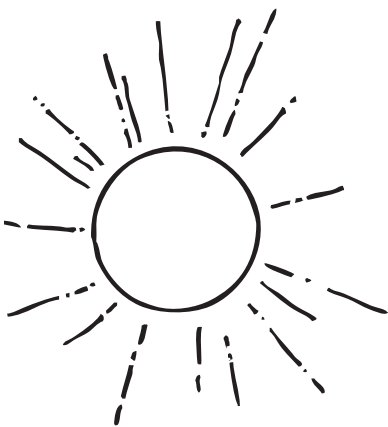
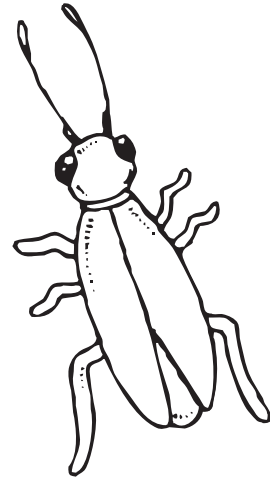
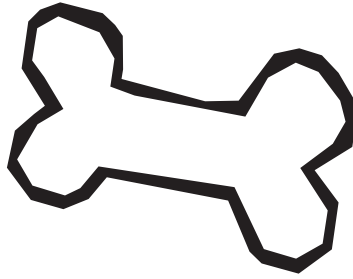
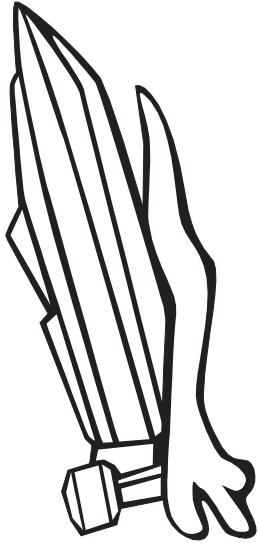

boat, bone, roach, sun, duck, rug



P.LSC-M.8

Letter-Sound Correspondence Cards – Medial

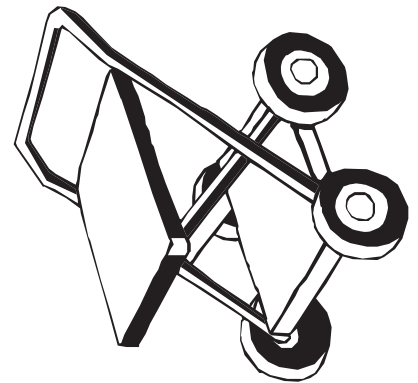
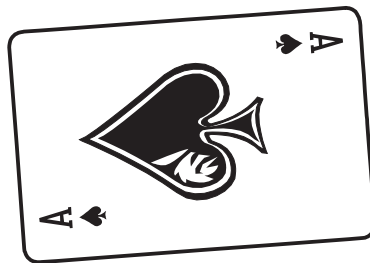
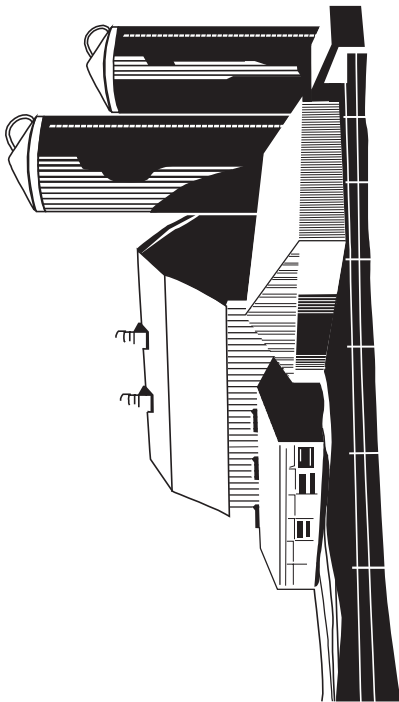
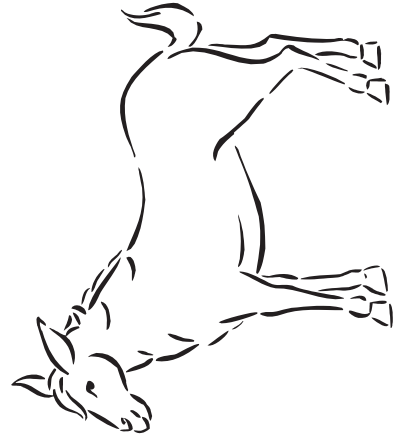
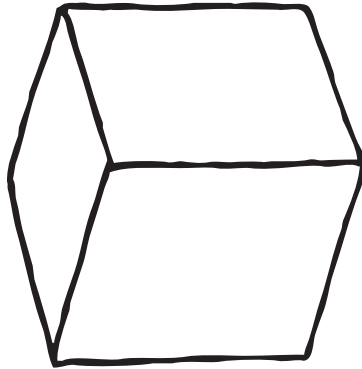

tub, cube, mule, farm, card, cart



# Phonics

Letter-Sound Correspondence Cards – Medial

P.LSC-M.9

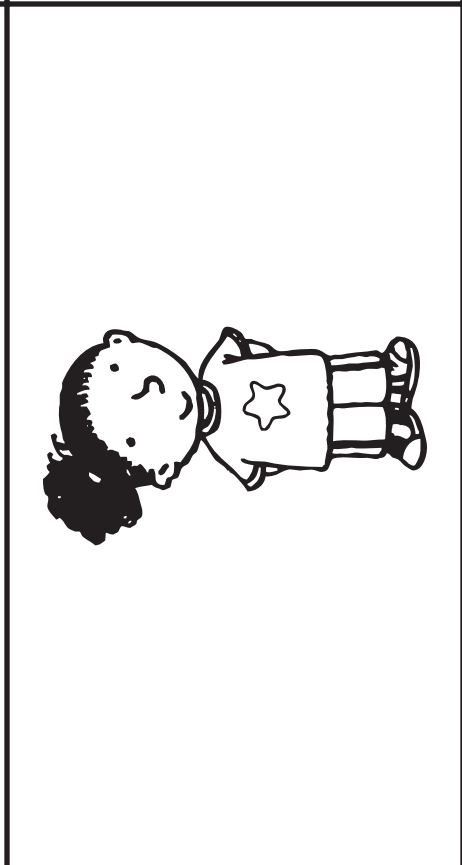
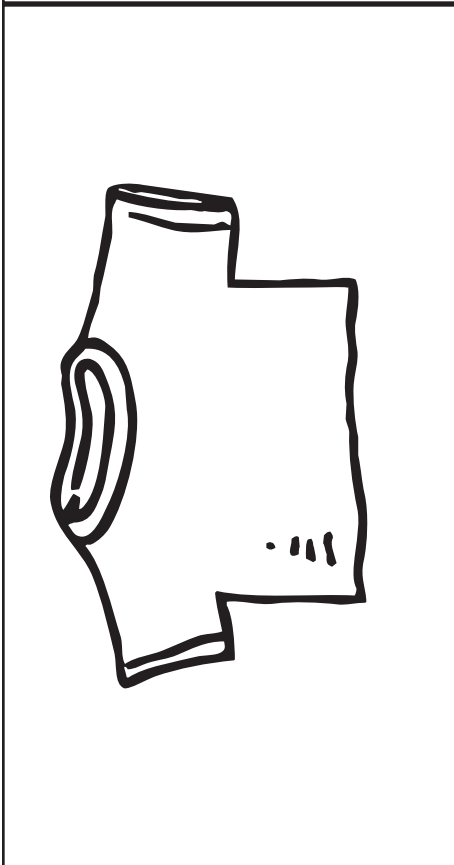
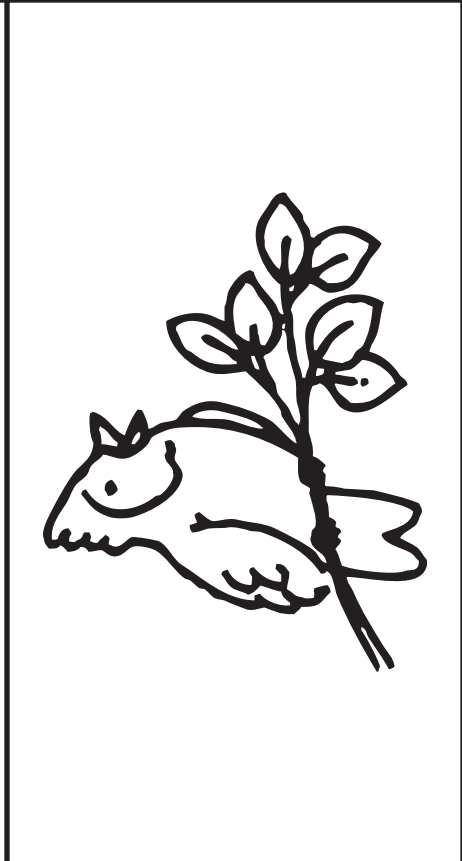
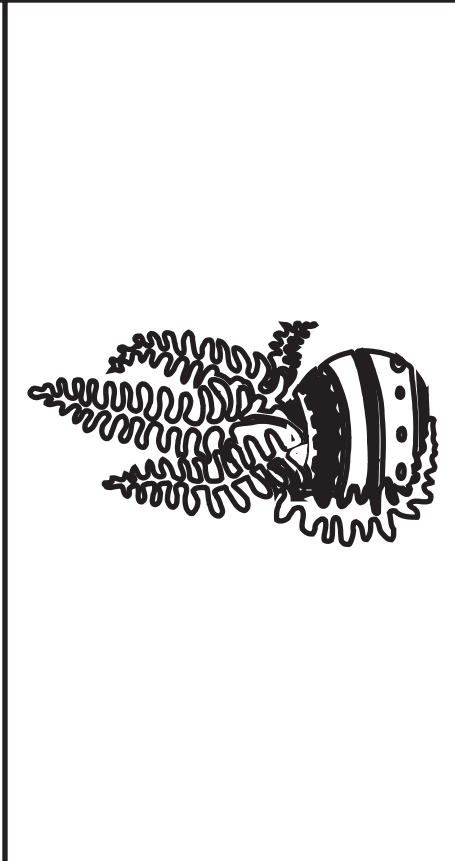
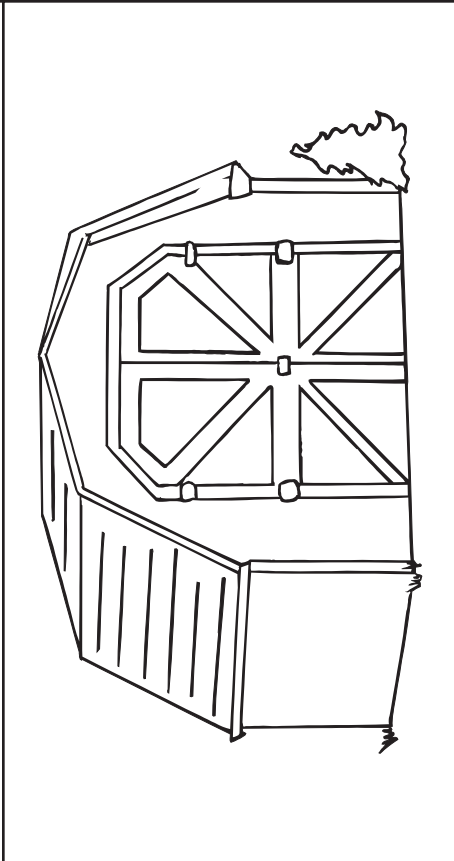

barn, fern, bird, shirt, dirt, girl



P.LSC-M.10

Letter-Sound Correspondence Cards – Medial

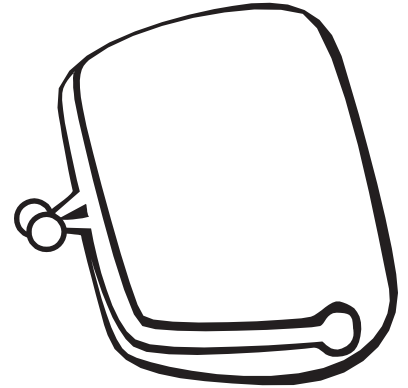
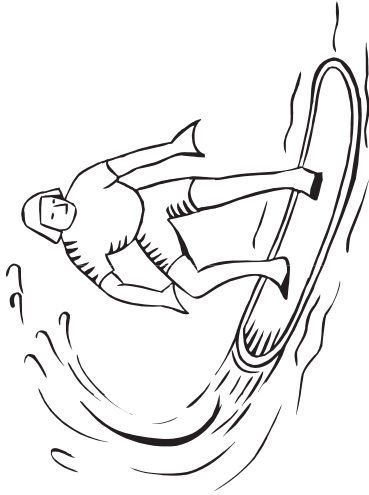

3rd

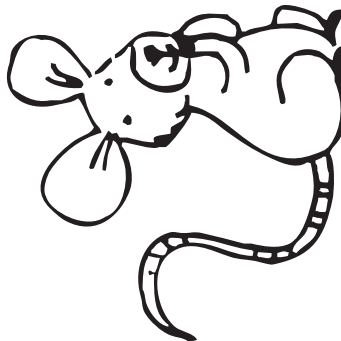

surf, nurse, purse, third, mouse, shower



# Phonics

Letter-Sound Correspondence Cards – Medial

P.LSC-M.1.1

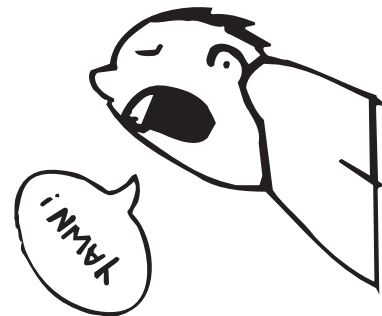
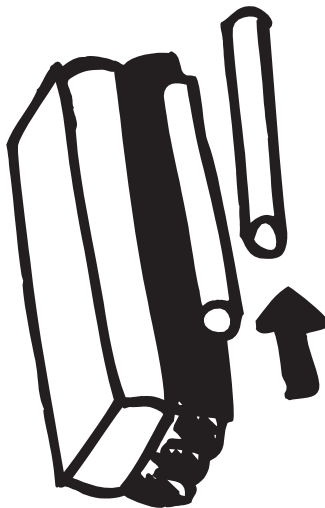
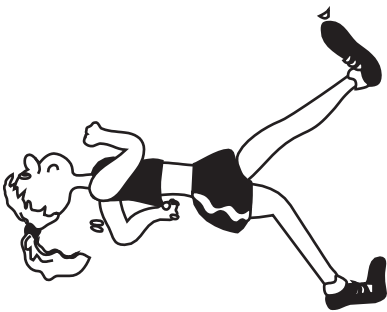
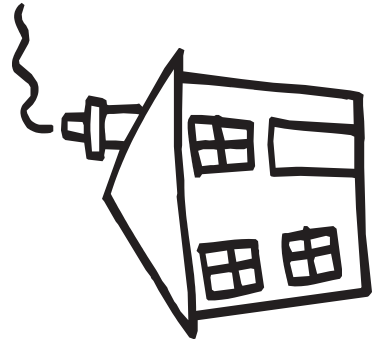
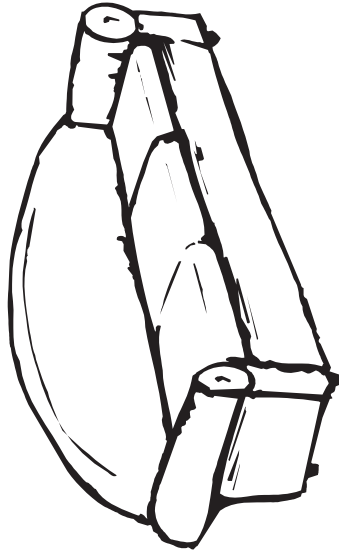
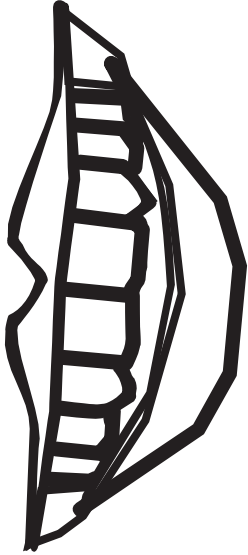

mouth, couch, house, walk, chalk, yawn



P.LSC-M.12

Letter-Sound Correspondence Cards – Medial

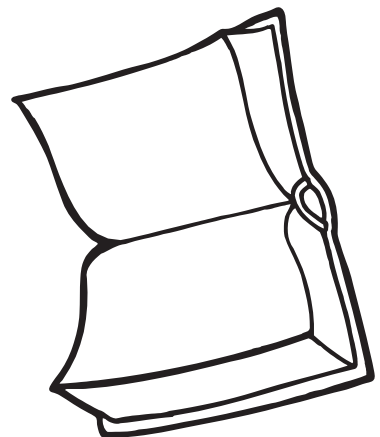
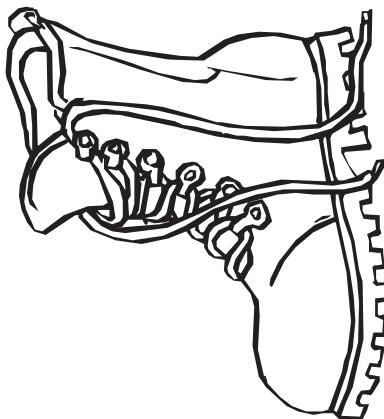
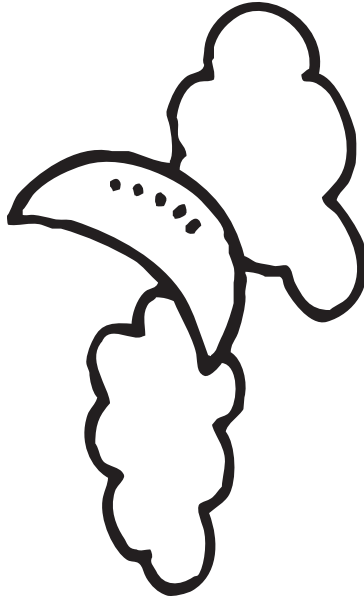
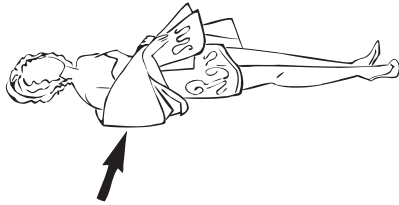

shawl, moon, pool, moose, boot, book



# Phonics

Letter-Sound Correspondence Cards – Medial

P.LSC-M.13

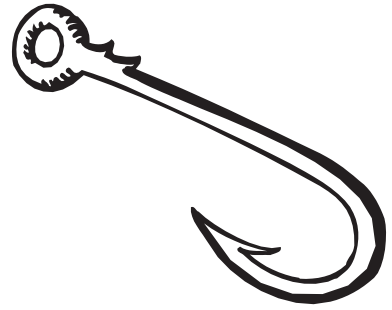
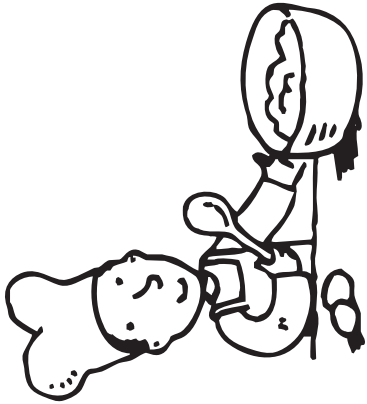

cook, foot, hook, coin, boil



P.LSC-F.1

Letter-Sound Correspondence Cards – Final

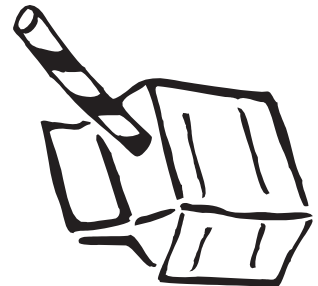
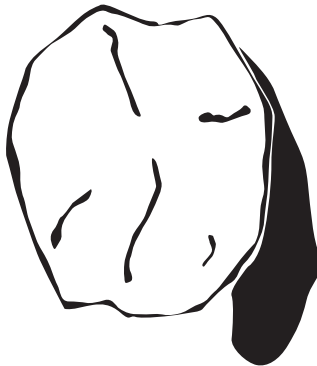
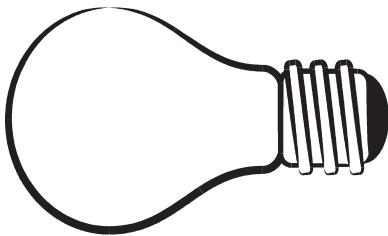
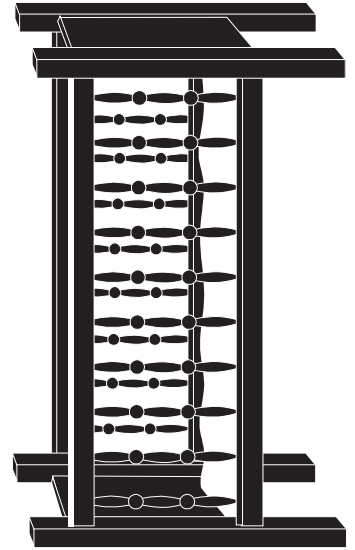
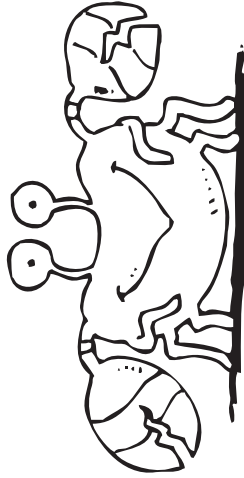
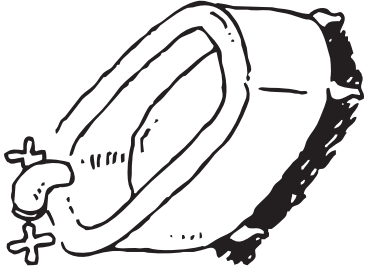

tub, crab, crib, bulb, rock, milk





# Phonics

Letter-Sound Correspondence Cards – Final

P.LSC-F.2

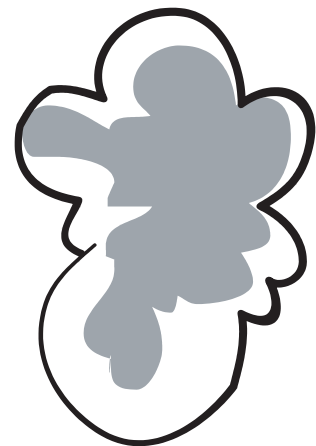
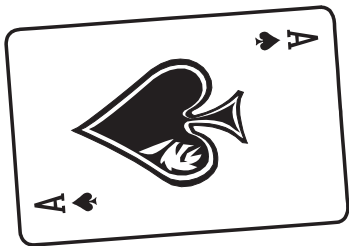
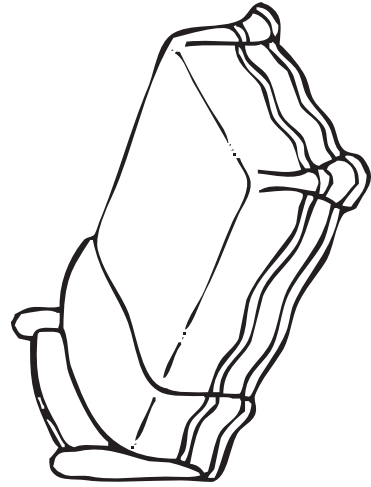
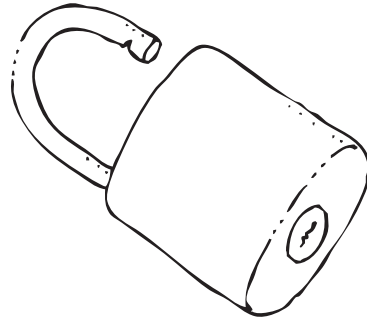
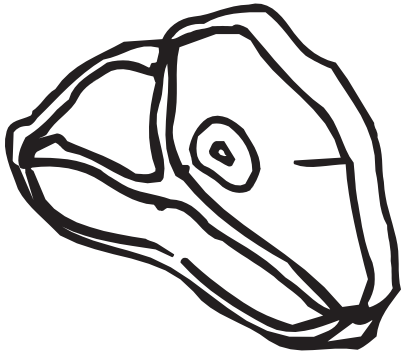

steak, lock, bed, card, bird, cloud



P.LSC-F.3

Letter-Sound Correspondence Cards – Final

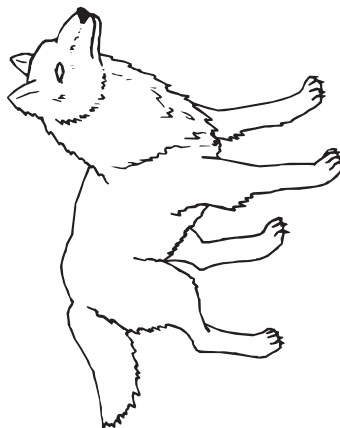
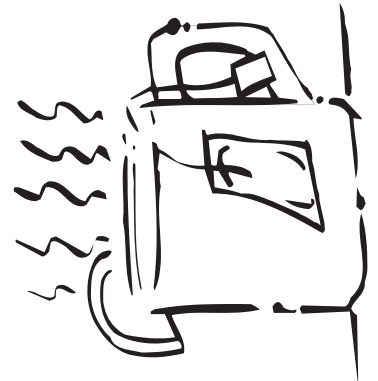

cookie, pea, tea, penny, wolf, elf



# Phonics

Letter-Sound Correspondence Cards – Final

P.LSC-F.4

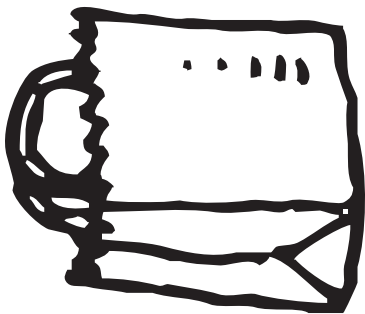
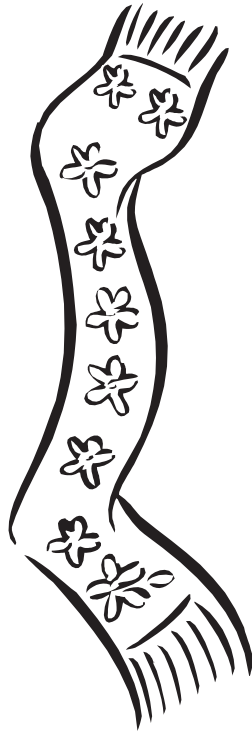
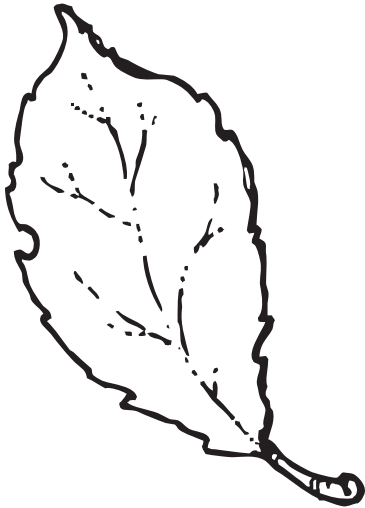

leaf, scarf, bug, bag, frog, log



P.LSC-F.5

Letter-Sound Correspondence Cards – Final

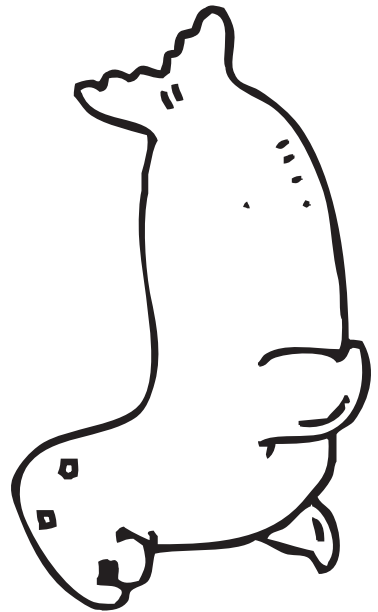
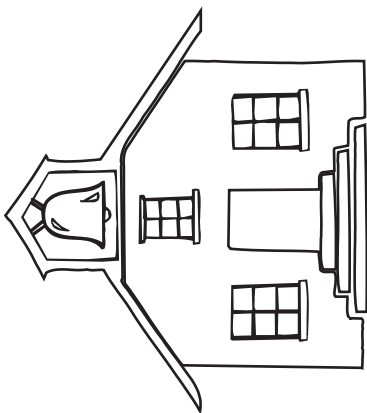
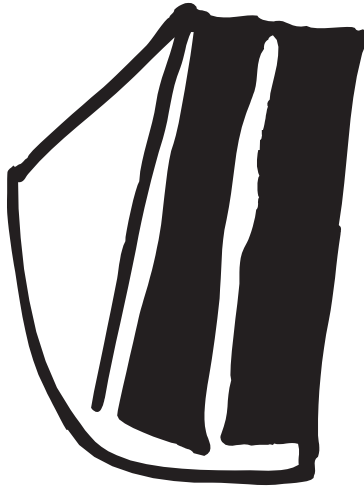
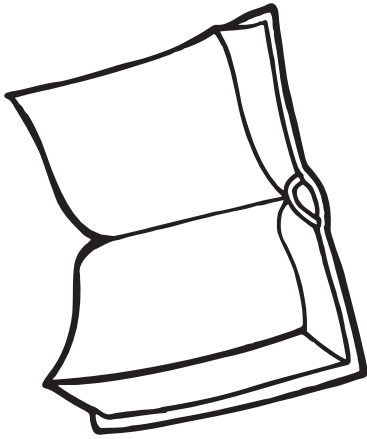

book, cake, stick, school, shovel, seal



# Phonics

Letter-Sound Correspondence Cards – Final

P.LSC-F.6

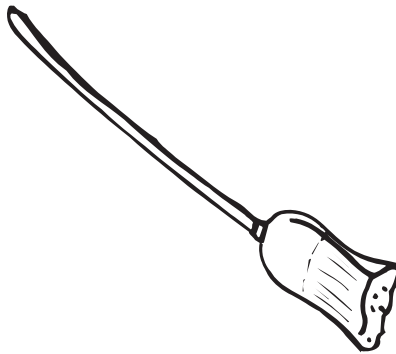
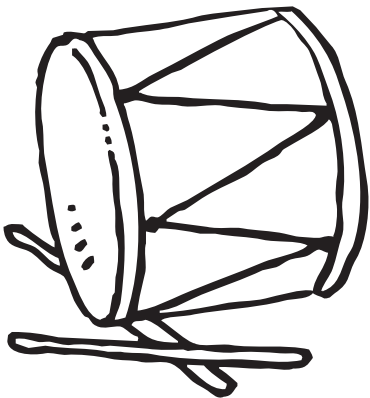
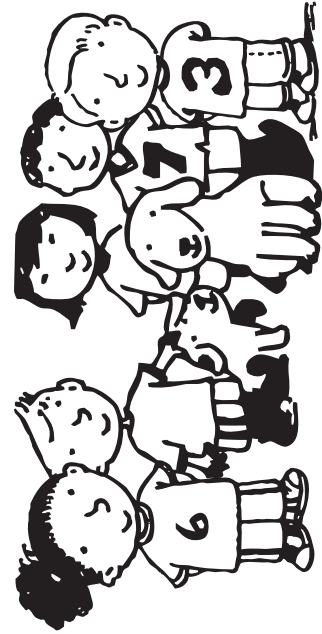
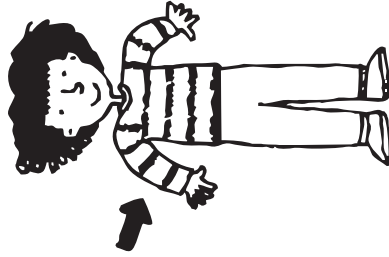
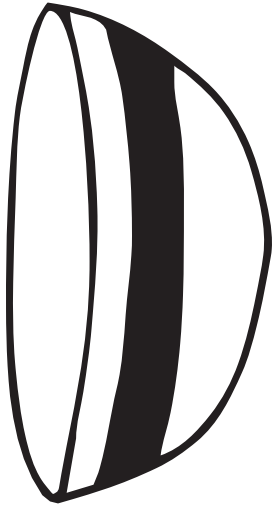

7

bowl, arm, team, drum, broom, seven



P.LSC-F.7

Letter-Sound Correspondence Cards – Final

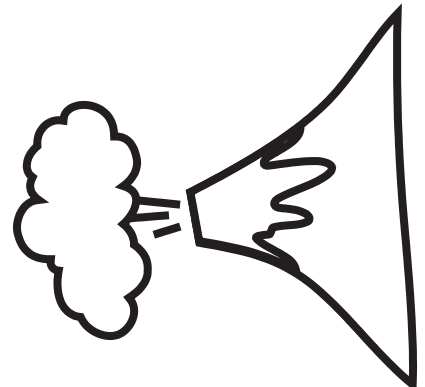
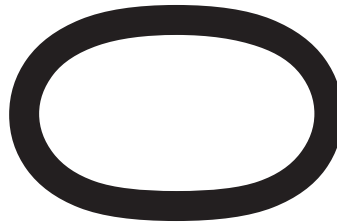
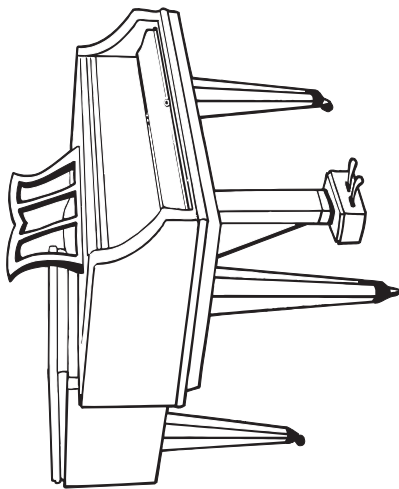
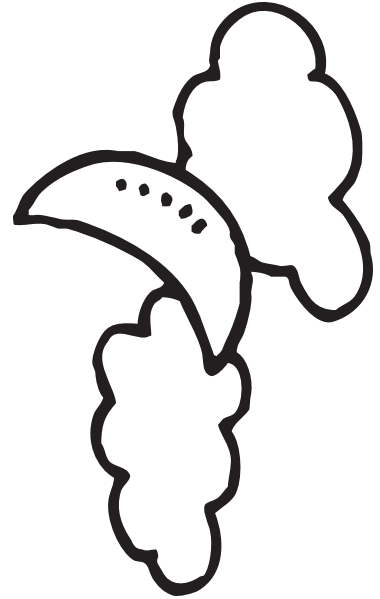
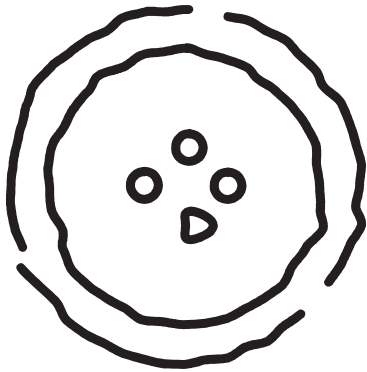

button, corn, moon, piano, zero, volcano



# Phonics

Letter-Sound Correspondence Cards – Final

P.LSC-F.8

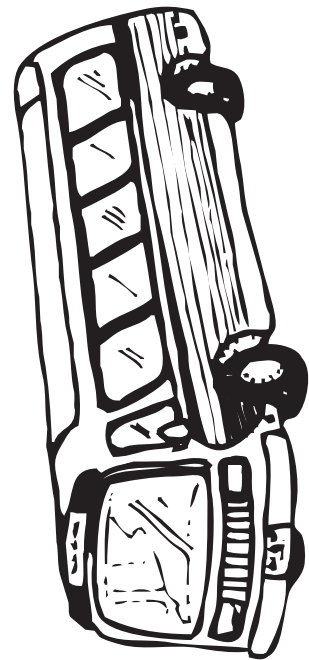
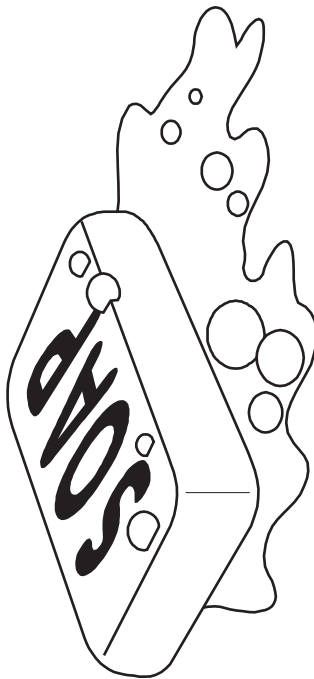
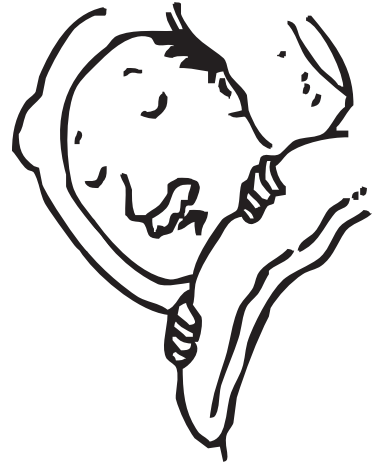
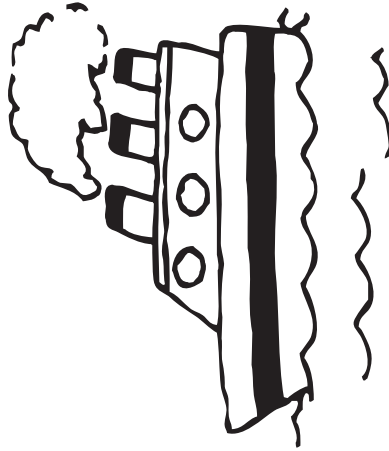

potato, ship, sleep, stop, soap, bus



P.LSC-F.9

Letter-Sound Correspondence Cards – Final

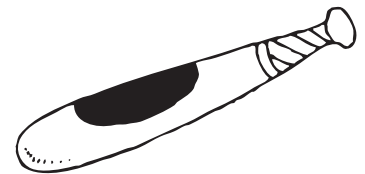

gas, kiss, octopus, carrot, boat, bat





# Phonics

Letter-Sound Correspondence Cards – Final

P.LSC-F.10

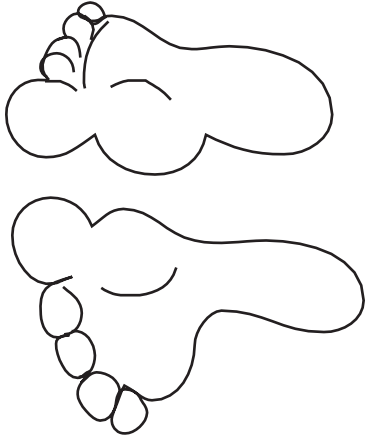

5

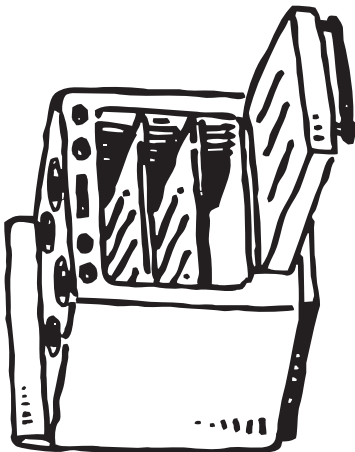

feet, five, sleeve, stove, cave, ox



P.LSC-F.1.1

Letter-Sound Correspondence Cards – Final

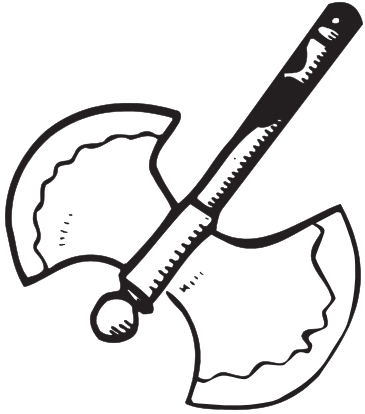

6

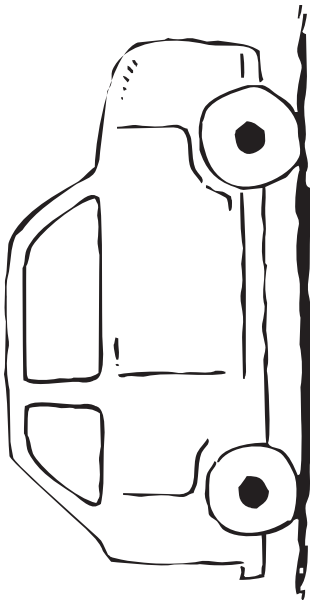
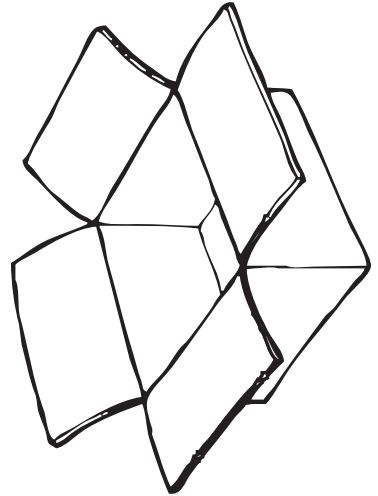

ax, six, box, car, star, jar



# Phonics

Letter-Sound Correspondence Cards – Final

P.LSC-F.12

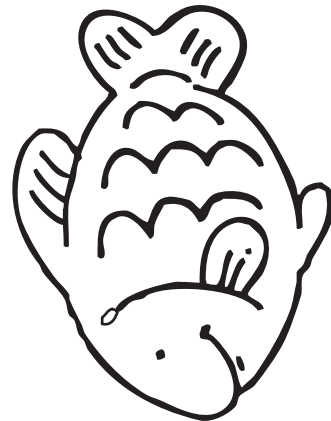
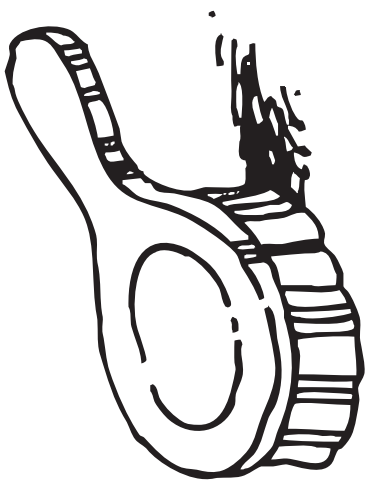
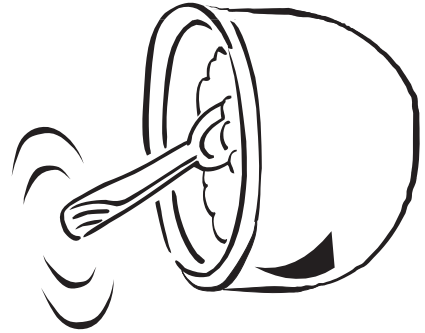

shower, river, stir, brush, dish, fish



P.LSC-F.13

Letter-Sound Correspondence Cards – Final

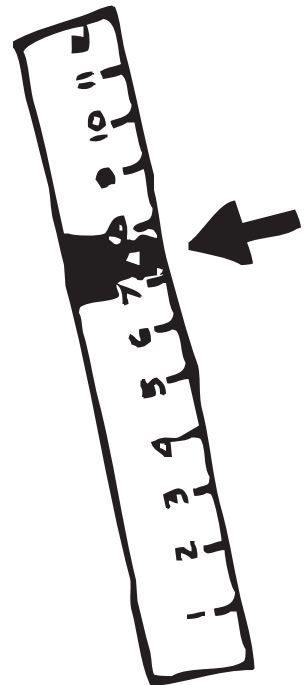
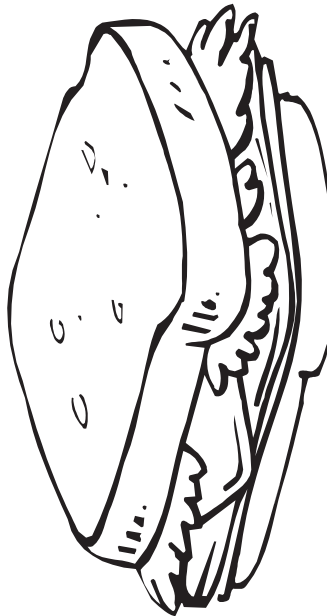
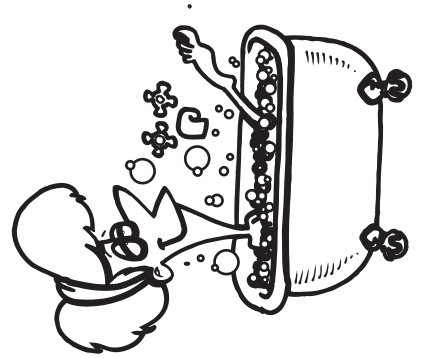

trash, tooth, bath, watch, sandwich, inch



# Phonics

Letter-Sound Correspondence Cards – Final

P.LSC-F.14

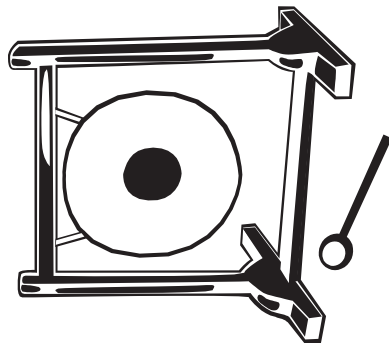
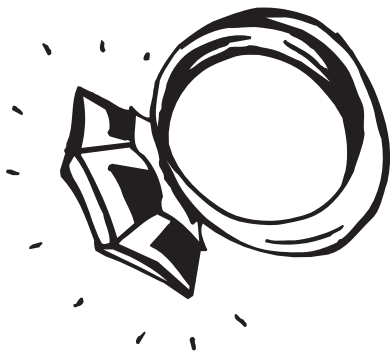
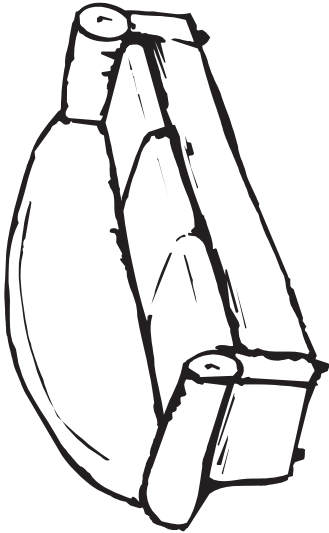

couch, king, swing, ring, gong, cow



P.LSC-F.15

Letter-Sound Correspondence Cards – Final

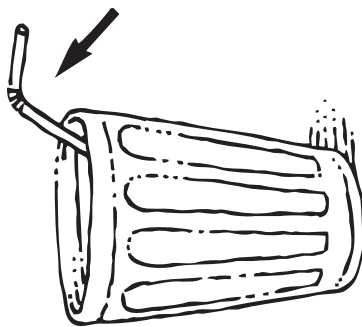
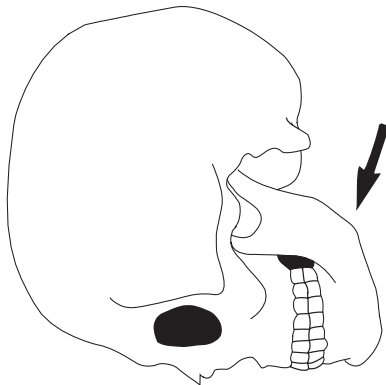
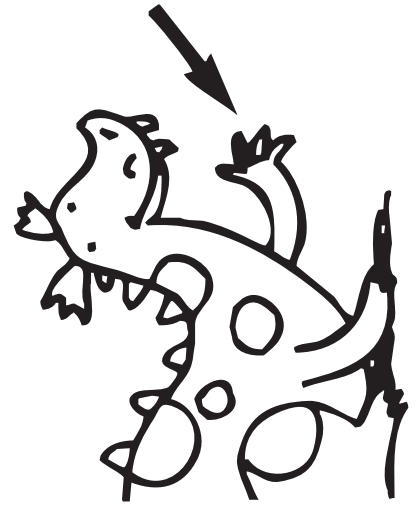
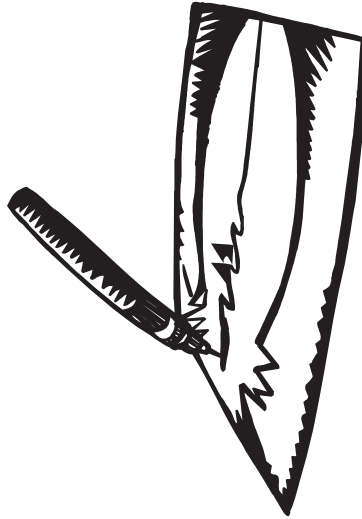

plow, draw, claw, jaw, straw, paw



# Phonics

Letter-Sound Correspondence Cards – Final

P.LSC-F.16

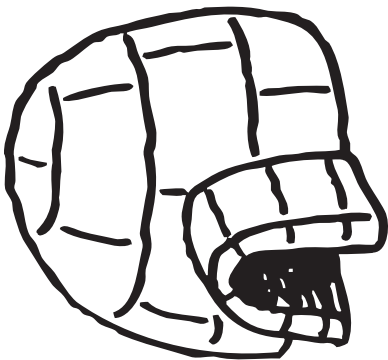
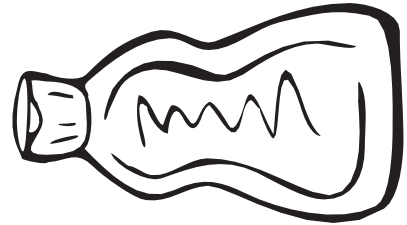
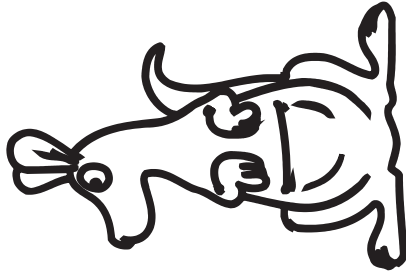

zoo, kangaroo, shampoo, igloo, boy, toy

